

ISO Cylinder **ISO Standard (15552)** **New**

Ø 32, Ø 40, Ø 50, Ø 63, Ø 80, Ø 100, Ø 125

Lightweight **Up to 15% Weight reduced**

* Compared with the previous CP96 series (Ø 40, 100 stroke)

New series added

- Standard type, Double rod: Series CP96-W
- Non-rotating rod type, Single rod: Series CP96K
Double rod: Series CP96K-W

Made to Order added

- Heat resistant cylinder (-XB6)
- Heavy duty scraper (-XC4)
- Coil scraper (-XC35) etc. are added.

■ By adopting a new cushion method (**Air cushion** + **Bumper cushion**),

Cycle time shortened

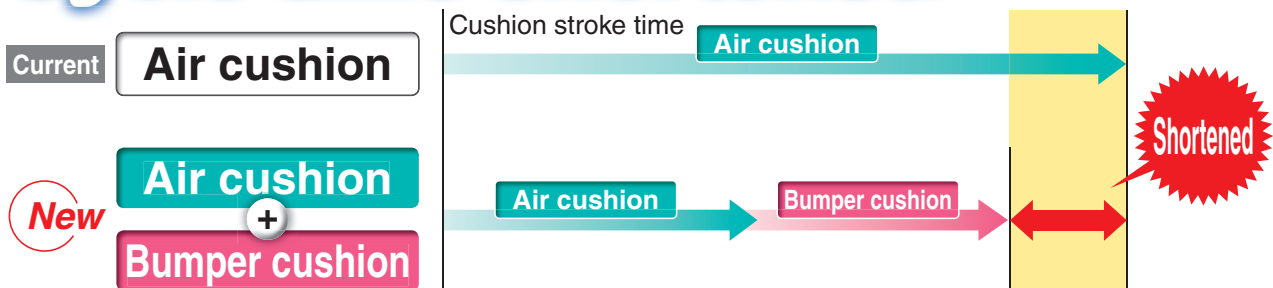

■ Bumper cushion reduces the metal noise that occurs when piston stops

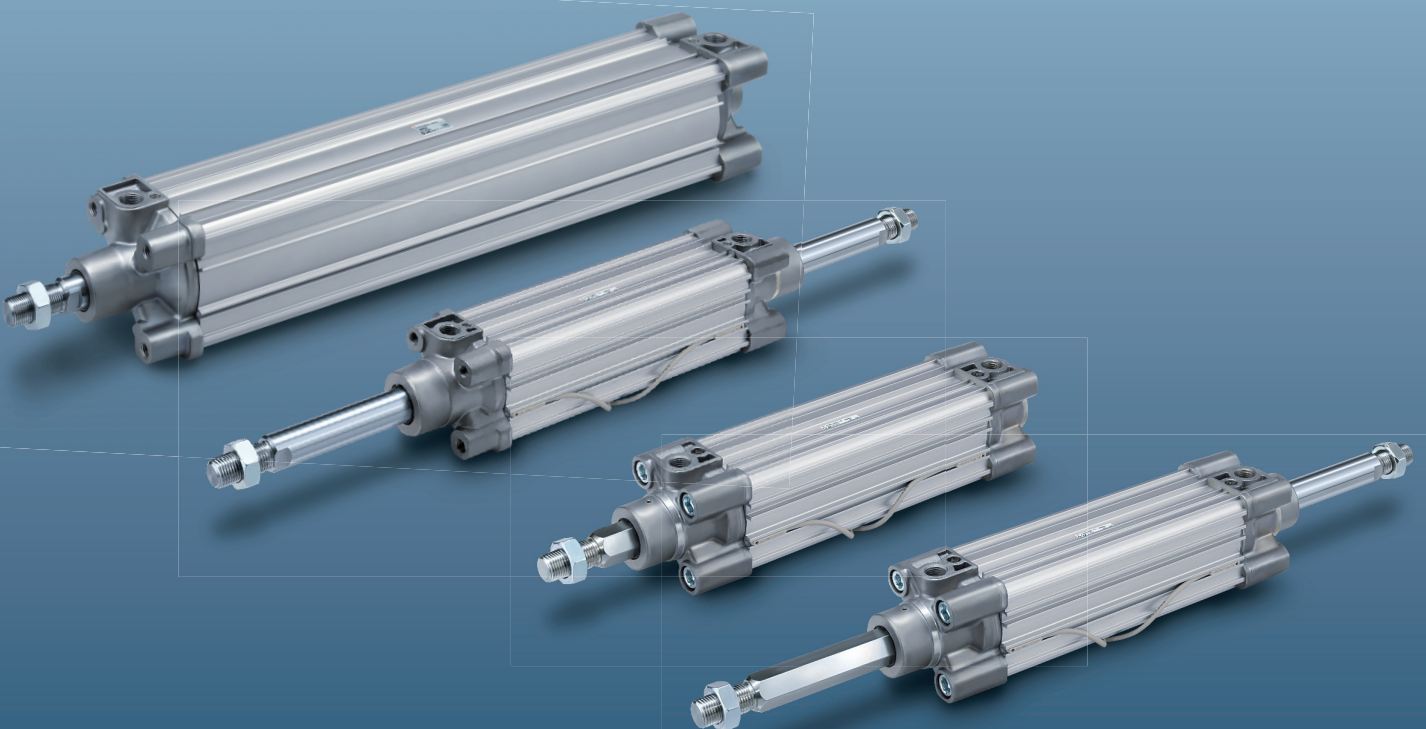

Series CP96



CAT.EUS20-241Bb-UK

New Series CP96

Weight reduced

Achieved weight reduction by changing rod cover shape and piston structure

Bore size [mm]	CP96	Reduction rate
32	0.74	11 %
40	1.02	15 %
50	1.74	11 %
63	2.12	12 %
80	3.40	11 %
100	4.33	11 %

* Compared with the previous CP96 series (Ø 40, 100 stroke)

* Ø 125 maintains the structure

Air cushion + Bumper cushion Combined structure

- The cushion stroke time can now be reduced with the double cushioning, which improves the cycle time.
- The bumper cushion reduces the metal noise that occurs when the piston stops at the end of the stroke.

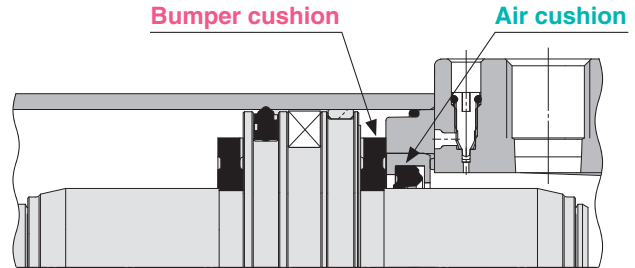

Rod end nut can be screwed up to TRP.

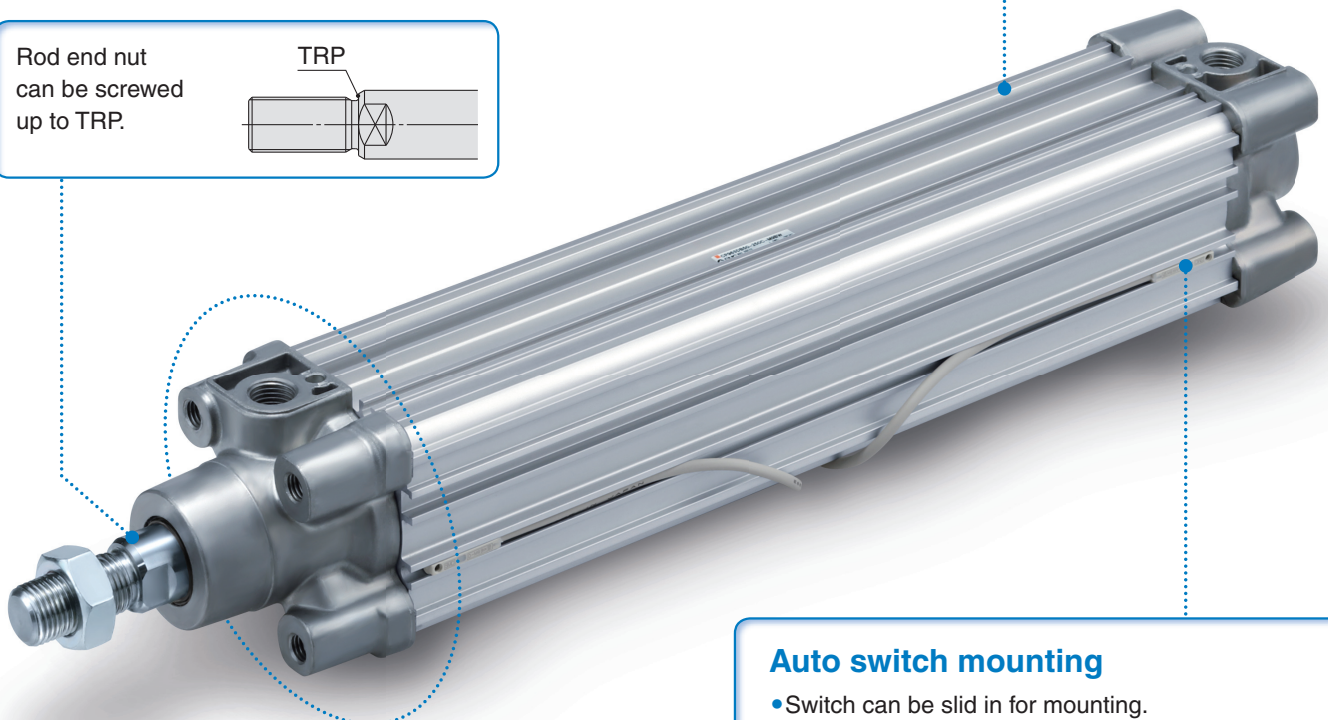
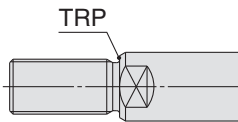

Auto switch mounting surface

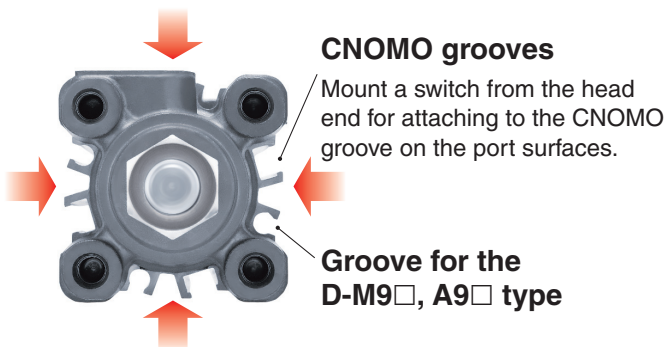

Auto switch mounting

- Switch can be slid in for mounting.
- Groove for M9, A9 switches and CNOMO groove are on all four sides. Max. four sides, slide-in mountable

Auto switch can be slid in.

Mountable from both the head end and the rod end.

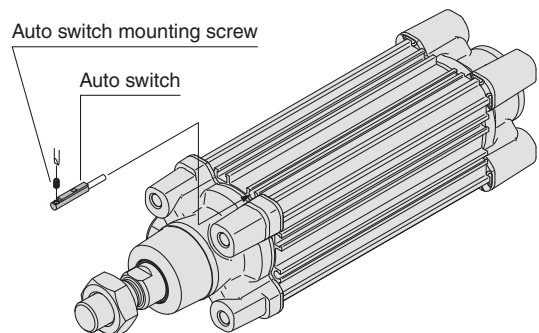

Various mounting bracket options

Mounting brackets can be combined according to the operating conditions.

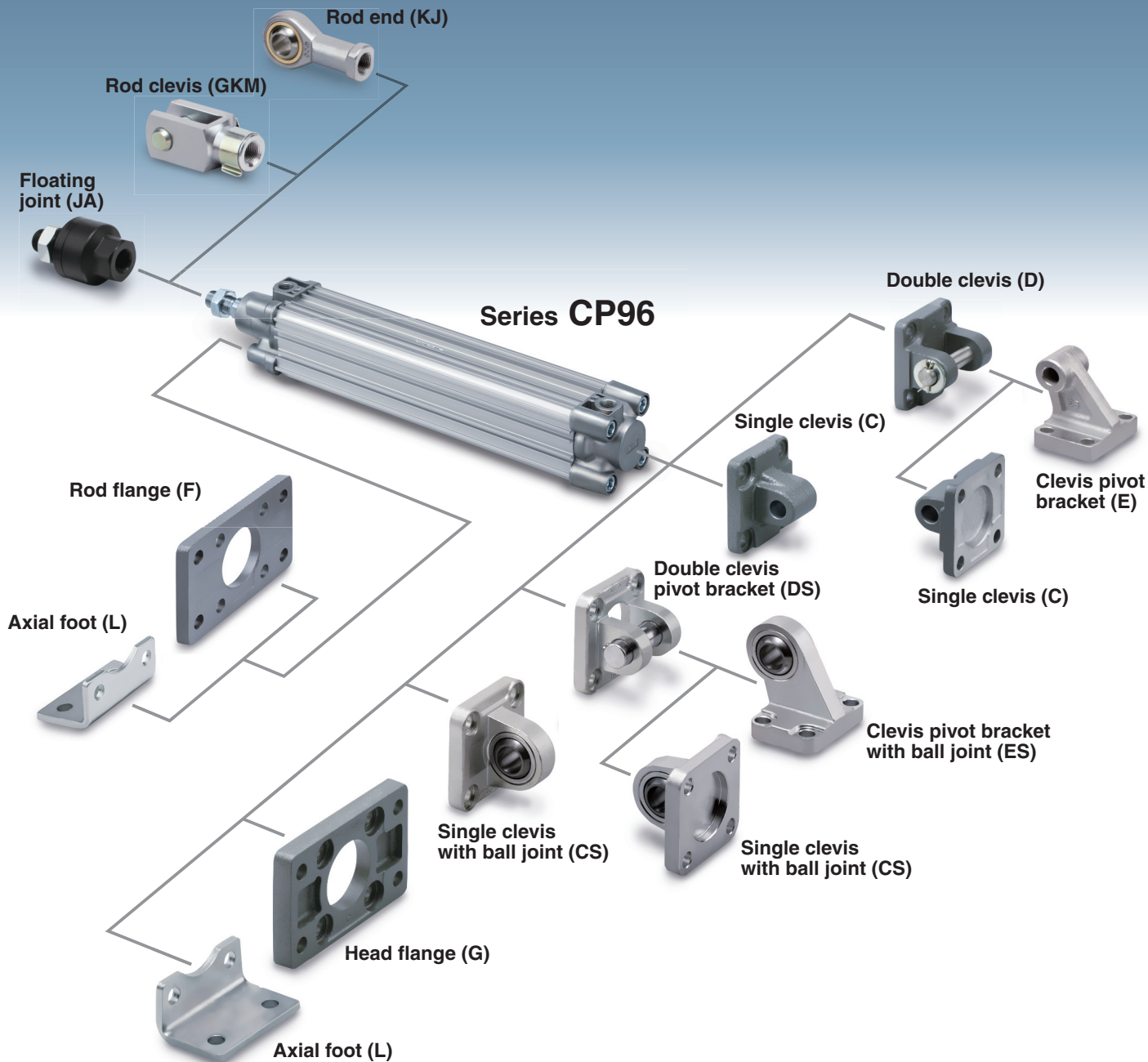

Series Variations

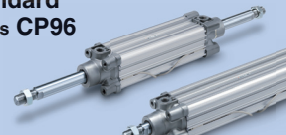
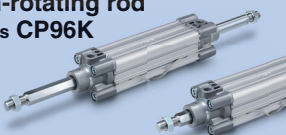
Series	Type	Bore size [mm]						Page
		32	40	50	63	80	100	
Standard Series CP96 	Double acting, Single rod	●	●	●	●	●	●	Page 3
	Double acting, Double rod	●	●	●	●	●	●	
Non-rotating rod Series CP96K 	Double acting, Single rod	●	●	●	●	●	●	Page 15
	Double acting, Double rod	●	●	●	●	●	●	

ISO Standard (15552)

Air Cylinder: Standard Type Double Acting, Single/Double Rod Series **CP96** Ø 32, Ø 40, Ø 50, Ø 63, Ø 80, Ø 100, Ø 125



How to Order

CP96S **B** **32** - **100** **C** **J** **W** - **□**

With auto switch **CP96SD** **B** **32** - **100** **C** **J** **W** - **M9BW** **S** - **□**

With auto switch (Built-in magnet)

Mounting

B	Basic
L	Axial foot
F	Rod flange
G	Head flange
C	Single clevis
D	Double clevis

* Mounting brackets are shipped together, (but not assembled).

Bore size

32	32 mm
40	40 mm
50	50 mm
63	63 mm
80	80 mm
100	100 mm
125	125 mm

Cylinder stroke [mm]
Refer to "Standard Strokes" on page 4.

Air cushion on both ends + Bumper cushion
* Remove "C" when selecting Ø 125 (Air cushion on both ends)

Number of auto switches

—	2 pcs.
S	1 pc.
3	3 pcs.
n	"n" pcs.

Auto switch

—	Without auto switch
---	---------------------

* For applicable auto switches, refer to the table below.

Rod

—	Single rod
W	Double rod

Rod boot

—	Without rod boot
J	Nylon tarpaulin (One end)
JJ	Nylon tarpaulin (Both ends)
K	Heat resistant tarpaulin (One end)
KK	Heat resistant tarpaulin (Both ends)

Made to Order
Refer to page 4 for details.

Applicable Auto Switches/Refer to the Auto Switch Guide for further information on auto switches.

Type	Special function	Electrical entry	Indicator light	Wiring (Output)	Load voltage		Auto switch model	Lead wire length [m]				Pre-wired connector	Applicable load		
					DC	AC		0.5 (—)	1 (M)	3 (L)	5 (Z)		IC circuit	Relay, PLC	
Solid state auto switch	—	Grommet	No	3-wire (NPN)	24 V	5 V, 12 V	—	M9N	●	●	●	○	○	IC circuit	Relay, PLC
				3-wire (PNP)				M9P	●	●	●	○	○		
				2-wire				M9B	●	●	●	○	○		
	Diagnostic indication (2-colour indication)	Grommet	Yes	3-wire (NPN)	24 V	5 V, 12 V	—	M9NW	●	●	●	○	○	IC circuit	
				3-wire (PNP)				M9PW	●	●	●	○	○		
				2-wire				M9BW	●	●	●	○	○		
	Water resistant (2-colour indication)	Grommet	No	3-wire (NPN)	24 V	5 V, 12 V	—	M9NA*1	○	○	●	○	○	IC circuit	
				3-wire (PNP)				M9PA*1	○	○	●	○	○		
				2-wire				M9BA*1	○	○	●	○	○		
Reed auto switch	—	Grommet	Yes	3-wire (NPN equivalent)	24 V	12 V	100 V or less	A96	●	—	●	—	—	IC circuit	Relay, PLC
				2-wire				A93	●	●	●	●	—	—	
								A90	●	—	●	—	—	—	

*1 Water resistant type auto switches can be mounted on the above models, but in such case SMC cannot guarantee water resistance.

* Lead wire length symbols: 0.5 m — (Example) M9NW
1 m M (Example) M9NWM
3 m L (Example) M9NWL
5 m Z (Example) M9NWX

* Solid state auto switches marked with "○" are produced upon receipt of order.

* Since there are other applicable auto switches than listed above, refer to the Auto Switch Guide for details.

* For details about auto switches with pre-wired connector, refer to the Auto Switch Guide.

* The D-A9□/M9□/M9□W/M9□A auto switches are shipped together, (but not assembled).

(However, only the auto switch mounting brackets are assembled before shipment.)

Note) The D-Y59A, Y69A, Y7P, Y7□W, Z7□, Z80 cannot be mounted on the CP96 series.

Moreover, the D-M9□□ and A9□ auto switches cannot be mounted on square groove of the CP96 series.

Specifications

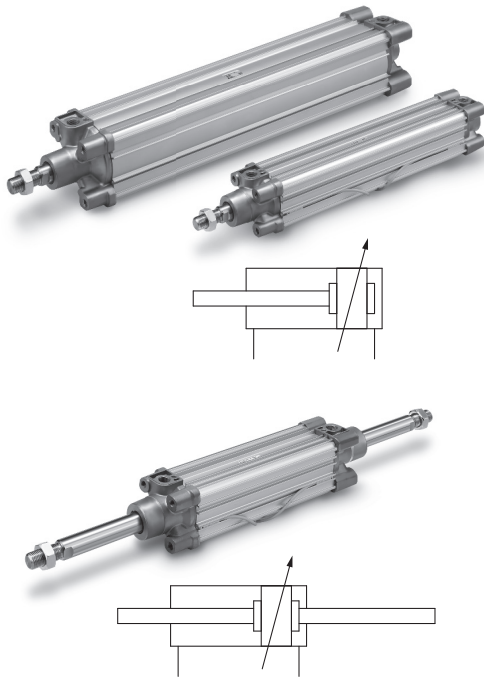

Bore size [mm]	32	40	50	63	80	100	125
Action	Double acting						
Fluid	Air						
Proof pressure	1.5 MPa						
Max. operating pressure	1.0 MPa						
Min. operating pressure	0.05 MPa						
Ambient and fluid temperature	Without auto switch: -20 to 70 °C (No freezing) With auto switch: -10 to 60 °C (No freezing)						
Lubrication	Not required (Non-lube)						
Operating piston speed	50 to 1000 mm/s					50 to 700 mm/s	
Allowable stroke tolerance	Up to 500 stroke: ${}^{+2}_0$, 501 to 1000 stroke: ${}^{+2.4}_0$, 1001 to 1500 stroke: ${}^{+2.8}_0$, 1501 to 2000 stroke: ${}^{+3.2}_0$						
Cushion	Air cushion on both ends + Bumper cushion					Air cushion on both ends	
Port size	G1/8	G1/4	G1/4	3/8	G3/8	G1/2	G1/2
Mounting	Basic, Axial foot, Rod flange, Head flange, Single clevis, Double clevis						

Standard Strokes

Bore size [mm]	Standard stroke [mm]	Max. stroke *
32	25, 50, 80, 100, 125, 160, 200, 250, 320, 400, 500	2000
40	25, 50, 80, 100, 125, 160, 200, 250, 320, 400, 500	2000
50	25, 50, 80, 100, 125, 160, 200, 250, 320, 400, 500, 600	2000
63	25, 50, 80, 100, 125, 160, 200, 250, 320, 400, 500, 600	2000
80	25, 50, 80, 100, 125, 160, 200, 250, 320, 400, 500, 600, 700, 800	2000
100	25, 50, 80, 100, 125, 160, 200, 250, 320, 400, 500, 600, 700, 800	2000
125	—	2000

Intermediate strokes are available.

* Please consult with SMC for longer strokes.

** Ø 125 and double rod are produced upon receipt of order.



Made to Order
 (For details, refer to pages 22 to 29.)

Symbol	Specifications
-XA□	Change of rod end shape
-XB6	Heat resistant cylinder (-10 to 150 °C)
-XC4	With heavy duty scraper
-XC7	Tie-rod, tie-rod nut, etc. made of stainless steel
-XC10	Dual stroke cylinder/Double rod type
-XC11	Dual stroke cylinder/Single rod type
-XC22	Fluororubber seal
-XC35	With coil scraper
-XC65	Made of stainless steel (Combination of -XC7 and -XC68)
-XC68	Made of stainless steel (with hard chrome plated piston rod)
-XC88	Spatter resistant coil scraper, Lube-retainer, grease for welding (Piston rod: Stainless steel 304)
-XC89	Spatter resistant coil scraper, Lube-retainer, grease for welding (Piston rod: S45C)

Refer to pages 19 and 20 for cylinders with auto switches.

- Auto switch proper mounting position (detection at stroke end)
- Minimum stroke for auto switch mounting
- Operating range
- How to mount and move the auto switch

Accessories

Mounting		Basic	Foot	Rod flange	Head flange	Single clevis	Double clevis
Standard	Rod end nut	●	●	●	●	●	●
	Clevis pin	—	—	—	—	—	●
Option	Rod end	●	●	●	●	●	●
	Rod clevis	●	●	●	●	●	●
	Rod boot	●	●	●	●	●	●

* Do not use a rod end (or floating joint) together with a single clevis with a ball joint (or clevis pivot bracket with a ball joint).

* Refer to pages 11 to 14 for dimensions and part numbers of the accessories.

⚠ Precautions

Be sure to read this before handling. Refer to the back cover for Safety Instructions. For Actuator and Auto Switch Precautions, refer to "Handling Precautions for SMC Products" and the Operation Manual on SMC website, <http://www.smc.eu>

Series CP96

Theoretical Output



Bore size [mm]	Rod size [mm]	Operating direction	Piston area [mm ²]	Operating pressure [MPa]								
				0.2	0.3	0.4	0.5	0.6	0.7	0.8	0.9	1.0
32	12	OUT	804	161	241	322	402	482	563	643	724	804
		IN	691	138	207	276	346	415	484	553	622	691
40	16	OUT	1257	251	377	503	629	754	880	1006	1131	1257
		IN	1056	211	317	422	528	634	739	845	950	1056
50	20	OUT	1963	393	589	785	982	1178	1374	1570	1767	1963
		IN	1649	330	495	660	825	989	1154	1319	1484	1649
63	20	OUT	3117	623	935	1247	1559	1870	2182	2494	2805	3117
		IN	2803	561	841	1121	1402	1682	1962	2242	2523	2803
80	25	OUT	5027	1005	1508	2011	2514	3016	3519	4022	4524	5027
		IN	4536	907	1361	1814	2268	2722	3175	3629	4082	4536
100	25	OUT	7854	1571	2356	3142	3927	4712	5498	6283	7068	7854
		IN	7363	1473	2209	2945	3682	4418	5154	5890	6627	7363
125	32	OUT	12272	2454	3682	4909	6136	7363	8590	9817	11045	12272
		IN	11468	2294	3440	4587	5734	6881	8027	9174	10321	11468

Note) Theoretical output [N] = Pressure [MPa] x Piston area [mm²]

Weights

Bore size [mm]		32	40	50	63	80	100	125
Basic weight	Basic	0.46	0.66	1.14	1.48	2.42	3.25	6.82
	Foot	0.16	0.20	0.38	0.46	0.89	1.09	2.60
	Flange	0.20	0.23	0.47	0.58	1.30	1.81	4.10
	Single clevis	0.16	0.23	0.37	0.60	1.07	1.73	4.15
	Double clevis	0.20	0.32	0.45	0.71	1.28	2.11	4.25
Additional weight per 50 mm of stroke	All mounting brackets	0.14	0.18	0.30	0.32	0.49	0.54	0.84
Accessories	Rod end	0.07	0.11	0.22	0.22	0.40	0.40	1.20
	Rod clevis	0.09	0.15	0.34	0.34	0.69	0.69	1.84

Calculation: Example) **CP96SD40-100C**

- Basic weight 0.66 [kg] (Basic, Ø 40)
- Additional weight 0.18 (kg/50 st)
- Cylinder stroke 100 [st]
- Mounting bracket weight 0.32 [kg] (Double clevis)

$$0.66 + 0.18 \times 100 \div 50 + 0.32 = 1.32 \text{ kg}$$

Allowable Kinetic Energy

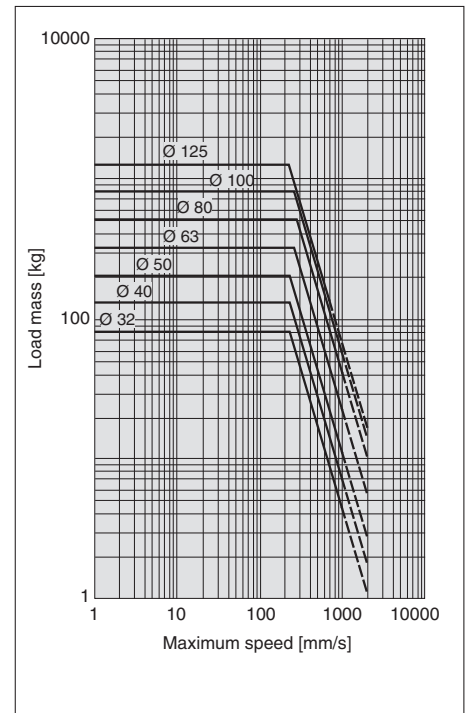

(Example) Find the upper limit of rod end load when an air cylinder of Ø 63 is operated at 500 mm/s. From a point indicating 500 mm/s on the axis of abscissas, extend a line upward and find a point where it intersects with a line for the 63 mm bore size. Extend a line from the intersection to the left and find a load mass 80 kg.

Construction

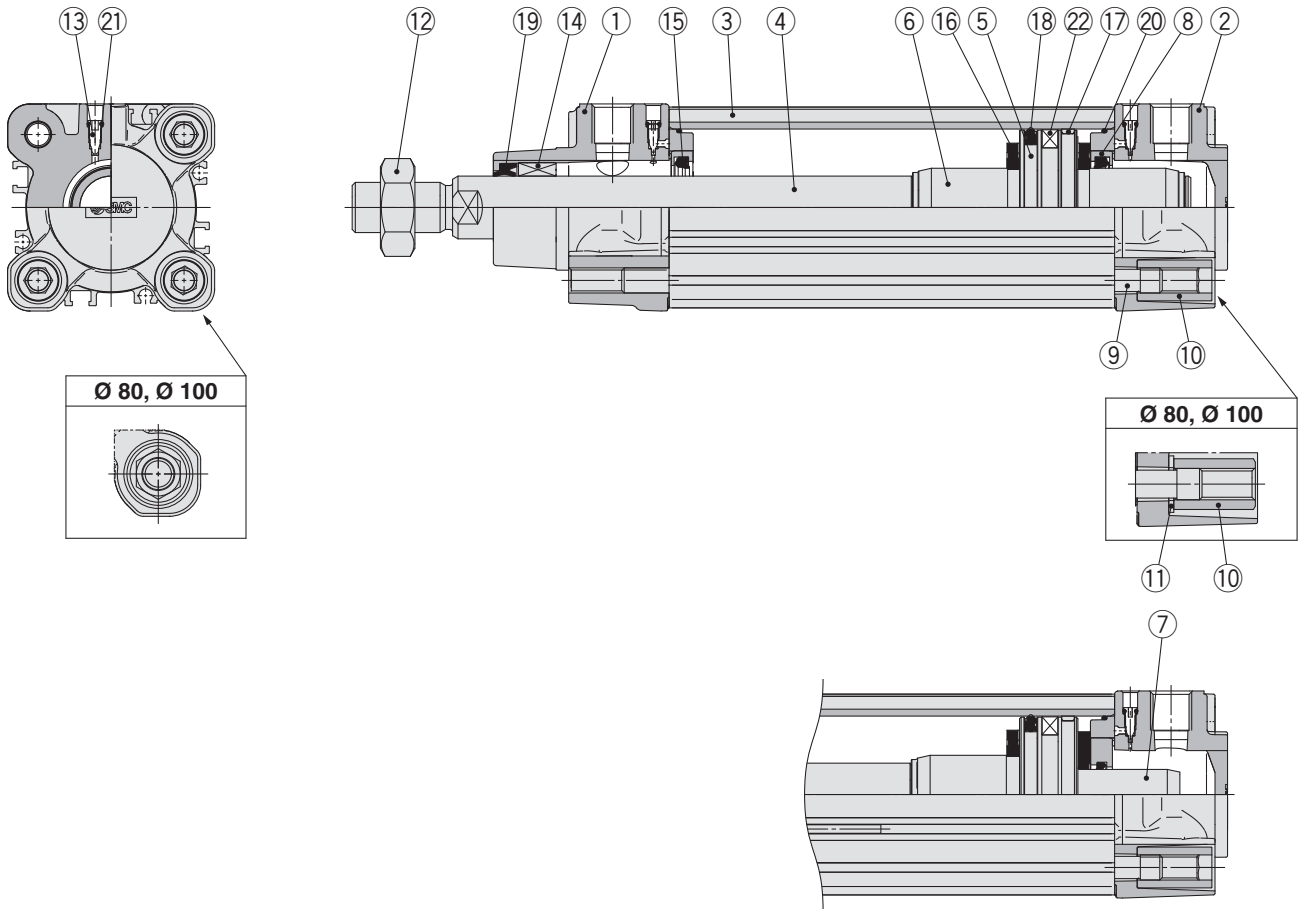

Component Parts

No.	Description	Material	Note
1	Rod cover	Aluminium die-cast	
2	Head cover	Aluminium die-cast	
3	Cylinder tube	Aluminium alloy	
4	Piston rod	Carbon steel	
5	Piston	Aluminium alloy	Ø 32 to Ø 63
		Aluminium die-cast	Ø 80, Ø 100
6	Cushion ring A	Aluminium alloy	
7	Cushion ring B	Aluminium alloy	
8	Cushion seal holder	Aluminium alloy	
9	Tie-rod	Carbon steel	
10	Tie-rod nut	Steel	
11	Flat washer	Steel	Ø 80, Ø 100
12	Rod end nut	Steel	
13	Cushion valve	Resin	
14	Bushing	Bearing alloy	
15	Cushion seal	Urethane	
16	Bumper	Urethane	
17	Wear ring	Resin	
18	Piston seal	NBR	
19	Rod seal	NBR	
20	Cylinder tube gasket	NBR	
21	Cushion valve seal	NBR	
22	Magnet		

Replacement Parts/Seal Kit (Single rod)

Bore size [mm]	Kit no.	Contents
32	CS95-32	Kits include items ⑮, ⑰ to ⑳
40	CS95-40	
50	CS95-50	
63	CS95-63	
80	CS95-80	
100	CS96-100	
125	CS96-125	

* Seal kits consist of items ⑮, ⑰ to ⑳ and can be ordered by using the seal kit number corresponding to each bore size.

* The seal kit includes a grease pack (10 g for Ø 32 to Ø 50, 20 g for Ø 63 and Ø 80, 30 g for Ø 100).

Order with the following part number when only the grease pack is needed.

Grease pack part number: GR-S-010 (10 g), GR-S-020 (20 g)

Seal Kit (Double rod)

Bore size [mm]	Kit no.	Contents
32	CS95W-32	Kits include items ⑮, ⑱ to ㉑
40	CS95W-40	
50	CS95W-50	
63	CS95W-63	
80	CS95W-80	
100	CS96W-100	
125	CS96W-125	

* Seal kits consist of items ⑮, ⑱ to ㉑ and can be ordered by using the seal kit number corresponding to each bore size.

* The seal kit includes a grease pack (10 g for Ø 32 to Ø 50, 20 g for Ø 63 and Ø 80, 30 g for Ø 100).

Order with the following part number when only the grease pack is needed.

Grease pack part number: GR-S010 (10 g), GR-S020 (20 g)

Series CP96

Dimensions

Basic: CP96S (D) B Bore size - Stroke C (J)

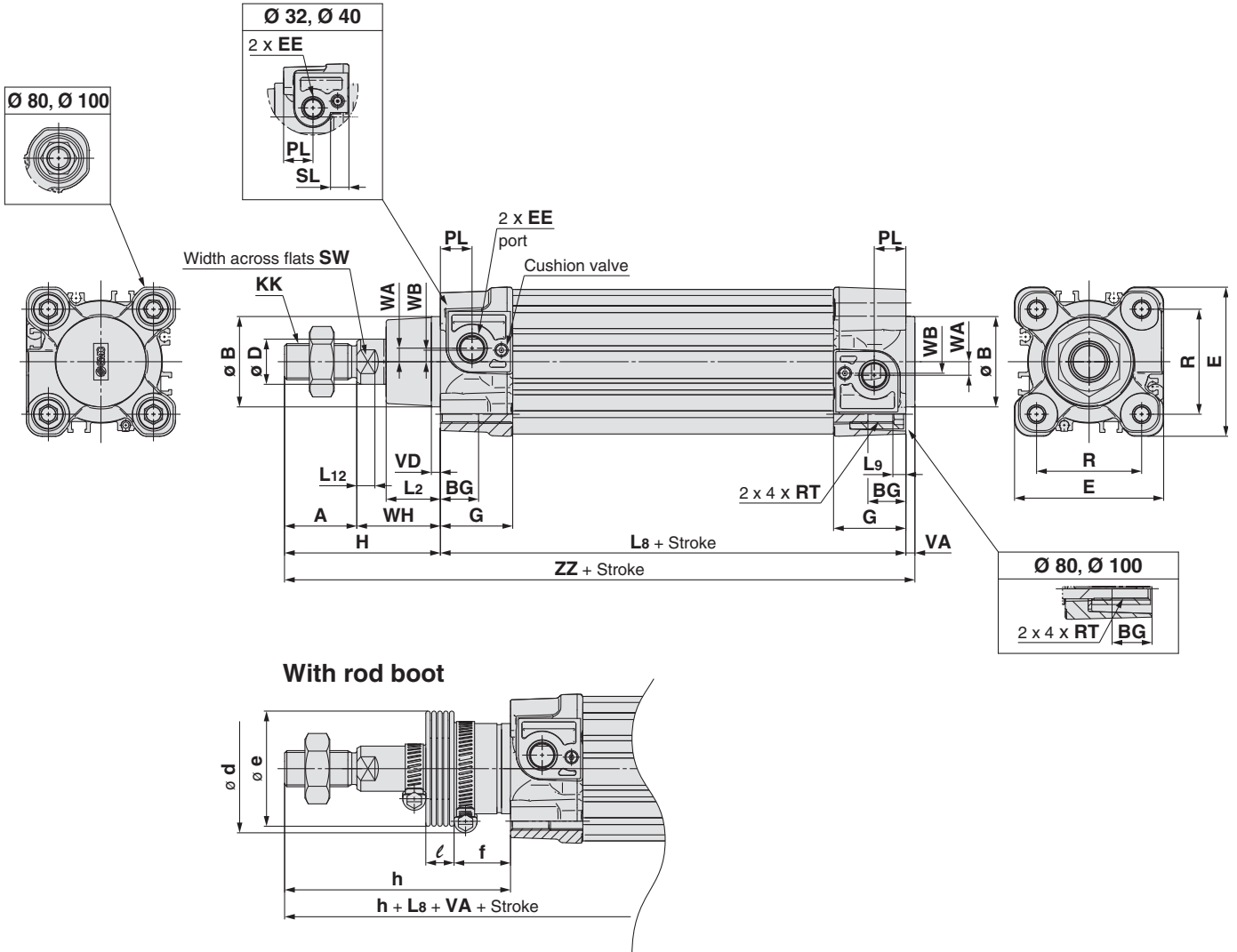

Bore size [mm]	Stroke range [mm]		A	Ø B d11	BG	Ø D	E	EE	G	H	KK	L2	L8	L9	L12	PL	R	RT	SL	SW	VA	VD	WA	WB	WH	ZZ
	Without rod boot	With rod boot																								
32	Up to 2000	Up to 1000	22	30	16	12	47	G1/8	28.9	48	M10 x 1.25	15	94	4	6	13	32.5	M6 x 1	8	10	4	4	4	7	26	146
40	Up to 2000	Up to 1000	24	35	16	16	54	G1/4	32.6	54	M12 x 1.25	17	105	4	6.5	14	38	M6 x 1	8	13	4	4	5	8.9	30	163
50	Up to 2000	Up to 1000	32	40	16	20	66	G1/4	32	69	M16 x 1.5	24	106	5	8	14	46.5	M8 x 1.25	—	17	4	4	6	5.1	37	179
63	Up to 2000	Up to 1000	32	45	16	20	77	G3/8	38.6	69	M16 x 1.5	24	121	5	8	16	56.5	M8 x 1.25	—	17	4	4	9	6.3	37	194
80	Up to 2000	Up to 1000	40	45	17	25	99	G3/8	38.4	86	M20 x 1.5	30	128	—	10	16	72	M10 x 1.5	—	22	4	4	11.5	6	46	218
100	Up to 2000	Up to 1000	40	55	17	25	118	G1/2	42.9	91	M20 x 1.5	32	138	—	10	18	89	M10 x 1.5	—	22	4	4	17	10	51	233
125	Up to 2000	Up to 1000	54	60	20	32	144	G1/2	58	119	M27 x 2	40	160	—	—	19	110	M12 x 1.75	—	27	6	6	17	15	65	285

Bore size [mm]	H	Ø d	ø e	f	ℓ																h															
					1 to 50	51 to 100	101 to 150	151 to 200	201 to 300	301 to 400	401 to 500	501 to 600	601 to 700	701 to 800	801 to 900	901 to 1000	1 to 50	51 to 100	101 to 150	151 to 200	201 to 300	301 to 400	401 to 500	501 to 600	601 to 700	701 to 800	801 to 900	901 to 1000								
32	48	54	36	23	12.5	25	37.5	50	75	100	125	150	175	200	225	250	75	88	100	113	138	163	188	213	238	263	288	313								
40	54	54	36	23	12.5	25	37.5	50	75	100	125	150	175	200	225	250	75	88	100	113	138	163	188	213	238	263	288	313								
50	69	64	51	25	12.5	25	37.5	50	75	100	125	150	175	200	225	250	87	100	112	125	150	175	200	225	250	275	300	325								
63	69	64	51	25	12.5	25	37.5	50	75	100	125	150	175	200	225	250	87	100	112	125	150	175	200	225	250	275	300	325								
80	86	68	56	30	12.5	25	37.5	50	75	100	125	150	175	200	225	250	103	116	128	141	166	191	216	241	266	291	316	341								
100	91	76	56	32	12.5	25	37.5	50	75	100	125	150	175	200	225	250	103	116	128	141	166	191	216	241	266	291	316	341								
125	119	82	75	40	10	20	30	40	60	80	100	120	140	160	180	200	130	140	150	160	180	200	220	240	260	280	300	320								

Dimensions

Basic: CP96S (D) B Bore size – Stroke C (J) W

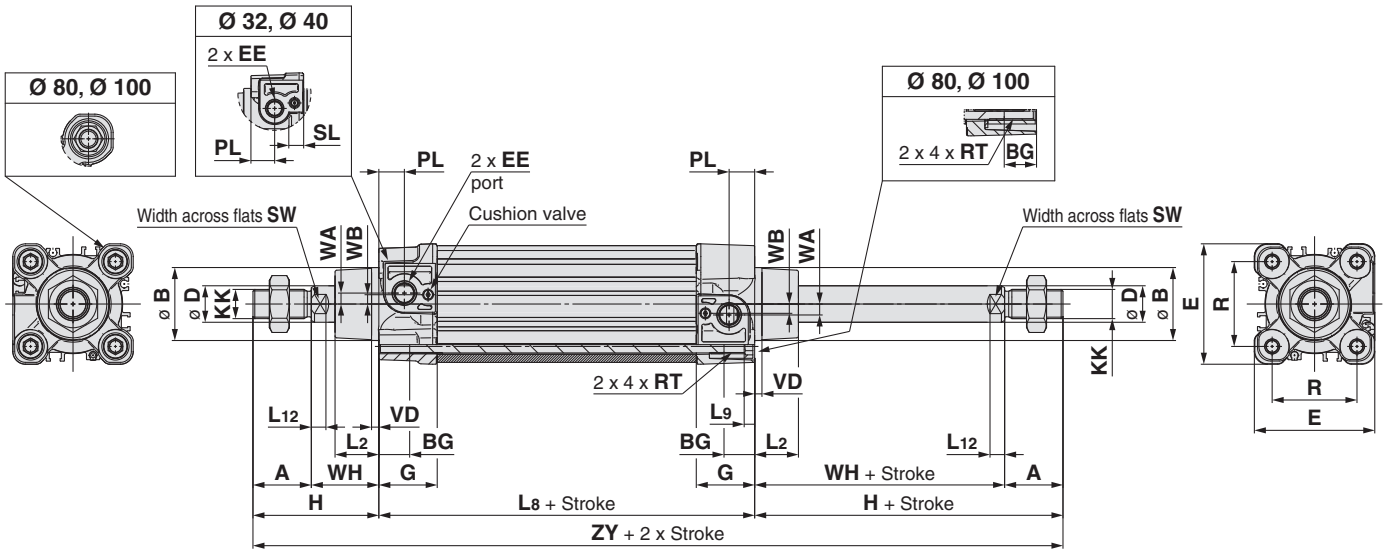

With rod boot at one end

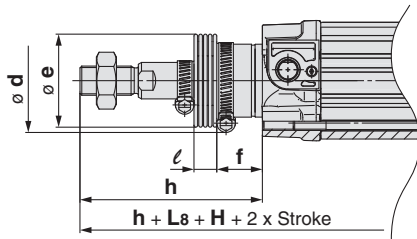

Bore size [mm]	Stroke range [mm]	A	Ø B d11	Ø D	EE	PL	RT	L12	KK	SW	G	BG	L8	VD	WA	WB	WH	ZY	E	R	L2	L9	H	SL
32	Up to 1000	22	30	12	G1/8	13	M6 x 1	6	M10 x 1.25	10	28.9	16	94	4	4	7	26	190	47	32.5	15	4	48	8
40	Up to 1000	24	35	16	G1/4	14	M6 x 1	6.5	M12 x 1.25	13	32.6	16	105	4	5	8.9	30	213	54	38	17	4	54	8
50	Up to 1000	32	40	20	G1/4	14	M8 x 1.25	8	M16 x 1.5	17	32	16	106	4	6	5.1	37	244	66	46.5	24	5	69	—
63	Up to 1000	32	45	20	G3/8	16	M8 x 1.25	8	M16 x 1.5	17	38.6	16	121	4	9	6.3	37	259	77	56.5	24	5	69	—
80	Up to 1000	40	45	25	G3/8	16	M10 x 1.5	10	M20 x 1.5	22	38.4	17	128	4	11.5	6	46	300	99	72	30	—	86	—
100	Up to 1000	40	55	25	G1/2	18	M10 x 1.5	10	M20 x 1.5	22	42.9	17	138	4	17	10	51	320	118	89	32	—	91	—
125	Up to 1000	54	60	32	G1/2	19	M12 x 1.75	13	M27 x 2	27	58	20	160	6	17	15	65	398	—	—	40	—	119	—

Bore size [mm]	Ø e	Ø d	f	ℓ																h															
				1 to 50	51 to 100	101 to 150	151 to 200	201 to 300	301 to 400	401 to 500	501 to 600	601 to 700	701 to 800	801 to 900	901 to 1000	1 to 50	51 to 100	101 to 150	151 to 200	201 to 300	301 to 400	401 to 500	501 to 600	601 to 700	701 to 800	801 to 900	901 to 1000								
32	36	54	23	12.5	25	37.5	50	75	100	125	150	175	200	225	250	75	88	100	113	138	163	188	213	238	263	288	313								
40	36	54	23	12.5	25	37.5	50	75	100	125	150	175	200	225	250	75	88	100	113	138	163	188	213	238	263	288	313								
50	51	64	25	12.5	25	37.5	50	75	100	125	150	175	200	225	250	87	100	112	125	150	175	200	225	250	275	300	325								
63	51	64	25	12.5	25	37.5	50	75	100	125	150	175	200	225	250	87	100	112	125	150	175	200	225	250	275	300	325								
80	56	68	30	12.5	25	37.5	50	75	100	125	150	175	200	225	250	103	116	128	141	166	191	216	241	266	291	316	341								
100	56	76	32	12.5	25	37.5	50	75	100	125	150	175	200	225	250	103	116	128	141	166	191	216	241	266	291	316	341								
125	75	82	40	10	20	30	40	60	80	100	120	140	160	180	200	130	140	150	160	180	200	220	240	260	280	300	320								

Series CP96

Dimensions

Basic: CP96S (D) B Bore size – Stroke C (JJ) W

With rod boot at both ends

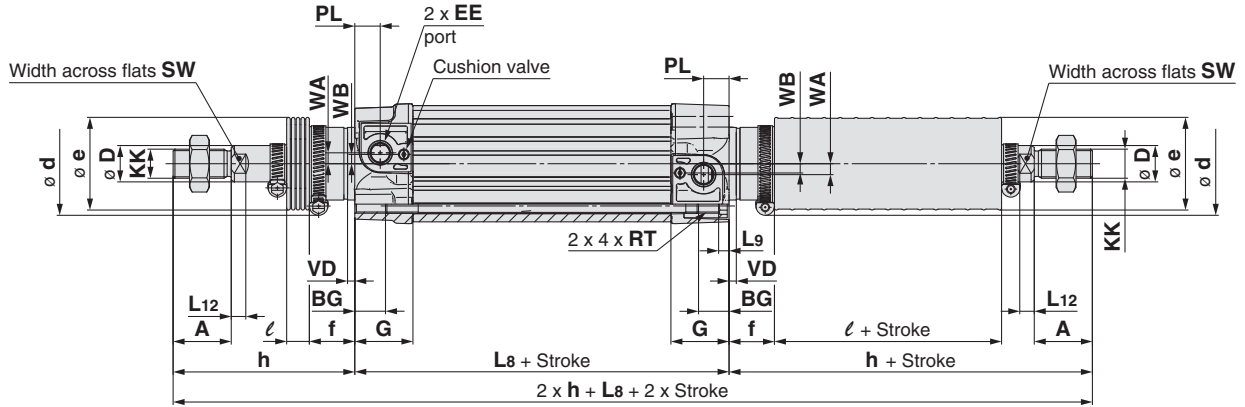

Bore size [mm]	Stroke range [mm]	A	Ø D	EE	PL	RT	L12	KK	SW	G	BG	L8	VD	WA	WB	E	R	L9	SL
32	Up to 1000	22	12	G1/8	13	M6 x 1	6	M10 x 1.25	10	28.9	16	94	4	4	7	47	32.5	4	8
40	Up to 1000	24	16	G1/4	14	M6 x 1	6.5	M12 x 1.25	13	32.6	16	105	4	5	8.9	54	38	4	8
50	Up to 1000	32	20	G1/4	14	M8 x 1.25	8	M16 x 1.5	17	32	16	106	4	6	5.1	66	46.5	5	—
63	Up to 1000	32	20	G3/8	16	M8 x 1.25	8	M16 x 1.5	17	38.6	16	121	4	9	6.3	77	56.5	5	—
80	Up to 1000	40	25	G3/8	16	M10 x 1.5	10	M20 x 1.5	22	38.4	17	128	4	11.5	6	99	72	—	—
100	Up to 1000	40	25	G1/2	18	M10 x 1.5	10	M20 x 1.5	22	42.9	17	138	4	17	10	118	89	—	—
125	Up to 1000	54	32	G1/2	19	M12 x 1.75	13	M27 x 2	27	58	20	160	6	17	15	144	110	—	—

Bore size [mm]	Ø e	Ø d	f	ℓ												h											
				1 to 50	51 to 100	101 to 150	151 to 200	201 to 300	301 to 400	401 to 500	501 to 600	601 to 700	701 to 800	801 to 900	901 to 1000	1 to 50	51 to 100	101 to 150	151 to 200	201 to 300	301 to 400	401 to 500	501 to 600	601 to 700	701 to 800	801 to 900	901 to 1000
32	36	54	23	12.5	25	37.5	50	75	100	125	150	175	200	225	250	75	88	100	113	138	163	188	213	238	263	288	313
40	36	54	23	12.5	25	37.5	50	75	100	125	150	175	200	225	250	75	88	100	113	138	163	188	213	238	263	288	313
50	51	64	25	12.5	25	37.5	50	75	100	125	150	175	200	225	250	87	100	112	125	150	175	200	225	250	275	300	325
63	51	64	25	12.5	25	37.5	50	75	100	125	150	175	200	225	250	87	100	112	125	150	175	200	225	250	275	300	325
80	56	68	30	12.5	25	37.5	50	75	100	125	150	175	200	225	250	103	116	128	141	166	191	216	241	266	291	316	341
100	56	76	32	12.5	25	37.5	50	75	100	125	150	175	200	225	250	103	116	128	141	166	191	216	241	266	291	316	341
125	75	82	40	10	20	30	40	60	80	100	120	140	160	180	200	130	140	150	160	180	200	220	240	260	280	300	320

Dimensions: With Mounting Bracket (Dimensions are common to single rod and double rod.)

Axial foot (L)

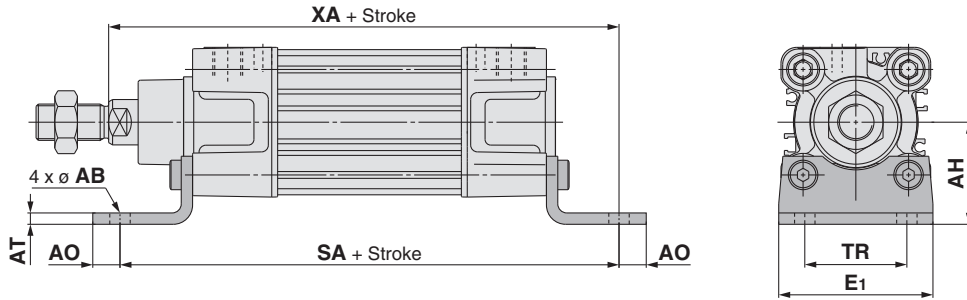

[mm]

Bore size [mm]	E1	TR	AH	AO	AT	AB	SA	XA
32	48	32	32	10	4.5	7	142	144
40	55	36	36	11	4.5	10	161	163
50	68	45	45	12	5.5	10	170	175
63	80	50	50	12	5.5	10	185	190
80	100	63	63	14	6.5	12	210	215
100	120	75	71	16	6.5	14.5	220	230
125	Max. 157	90	90	Max. 157	8	16	250	270

Rod flange (F)

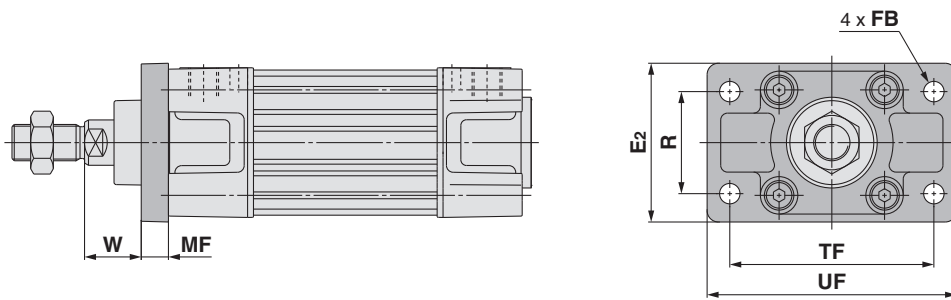

[mm]

Bore size [mm]	R	TF	FB	E2	UF	W	MF
32	32	64	7	50	79	16	10
40	36	72	9	55	90	20	10
50	45	90	9	70	110	25	12
63	50	100	9	80	120	25	12
80	63	126	12	100	153	30	16
100	75	150	14	120	178	35	16
125	90	180	16	Max. 157	Max. 124	45	20

Head flange (G)

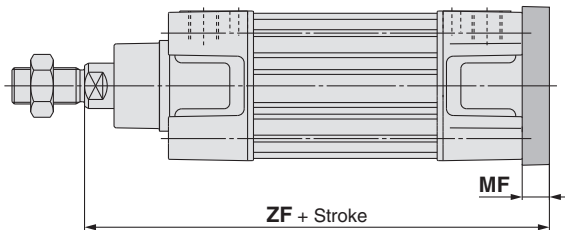

[mm]

Bore size [mm]	MF	ZF
32	10	130
40	10	145
50	12	155
63	12	170
80	16	190
100	16	205
125	20	245

**Single clevis (C)
 Double clevis (D)**

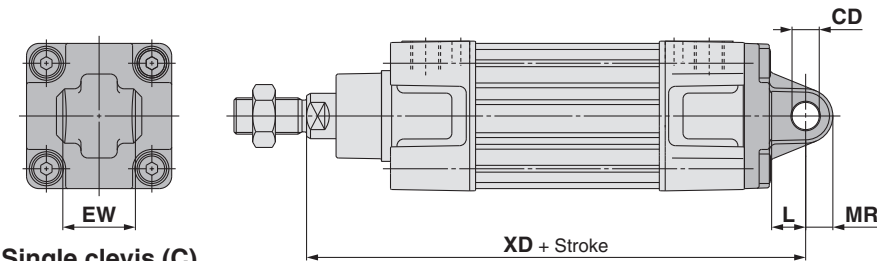

Single clevis (C)

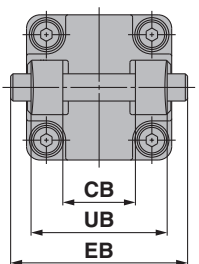

Double clevis (D)

[mm]

Bore size [mm]	EW	CD H9	L	MR	XD	UB h14	CB H14	EB
32	26 ^{-0.2} _{-0.6}	10	12	9.5	142	45	26	65
40	28 ^{-0.2} _{-0.6}	12	15	12	160	52	28	75
50	32 ^{-0.2} _{-0.6}	12	15	12	170	60	32	80
63	40 ^{-0.2} _{-0.6}	16	20	16	190	70	40	90
80	50 ^{-0.2} _{-0.6}	16	20	16	210	90	50	110
100	60 ^{-0.2} _{-0.6}	20	25	20	230	110	60	140
125	70 ^{-0.2} _{-0.6}	25	Min. 30	Max. 26	275	130	70	Max. 157

Series CP96 Accessories

Dimensions: Mounting Brackets

Axial foot (L)

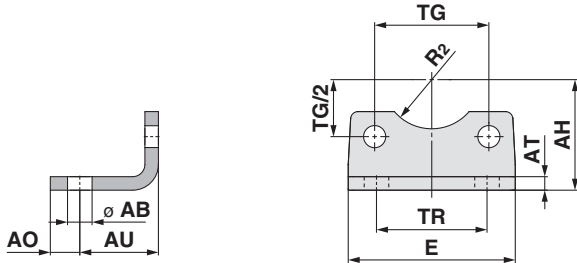

Bore size [mm]	Part no.	AB	TG ± 0.2	E	TR	AO	AU	AH	AT	R ₂	Screw size
32	L5032	7	32.5	48	32	10	24	32	4.5	15	M6 x 16L
40	L5040	10	38	55	36	11	28	36	4.5	17.5	M6 x 16L
50	L5050	10	46.5	68	45	12	32	45	5.5	20	M8 x 20L
63	L5063	10	56.5	80	50	12	32	50	5.5	22.5	M8 x 20L
80	L5080	12	72	100	63	14	41	63	6.5	22.5	M10 x 20L
100	L5100	14.5	89	120	75	16	41	71	6.5	27.5	M10 x 20L
125	L5125	116	110	Max.157	90	14	45	90	8	30	—

* Supplied with 4 mounting screws.

Flange (F, G)

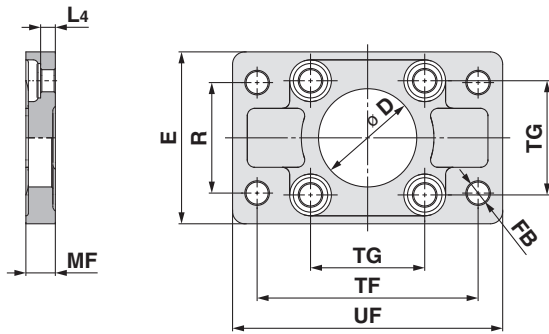

Bore size [mm]	Part no.	D H11	∅ FB	TG ± 0.2	E	R	MF	TF	UF	L ₄	Screw size
32	F5032	30	7	32.5	50	32	10	64	79	5	M6 x 20L
40	F5040	35	9	38	55	36	10	72	90	5	M6 x 20L
50	F5050	40	9	46.5	70	45	12	90	110	6.5	M8 x 20L
63	F5063	45	9	56.5	80	50	12	100	120	6.5	M8 x 20L
80	F5080	45	12	72	100	63	16	126	153	9	M10 x 25L
100	F5100	55	14	89	120	75	16	150	178	9	M10 x 25L
125	F5125	60	16	110	140	90	20	180	205	105	—

* Supplied with 4 mounting screws.

Single clevis (C)

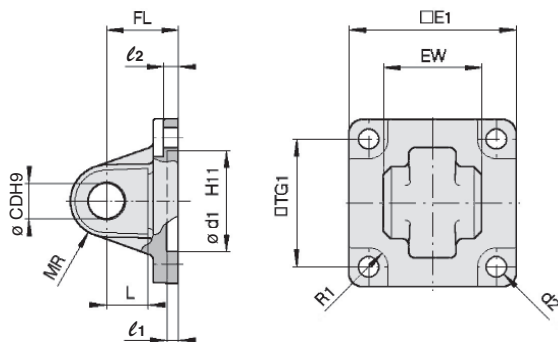

Bore size [mm]	Part no.	E ₁	EW	TG ₁	FL	l ₁	L	l ₂	∅ d ₁	∅ CD	MR	∅ d ₂	R ₁
32	C5032	45	26 ^{-0.2} _{-0.6}	32.5	22	5	12	5.5	30	10	9.5	6.6	6.5
40	C5040	51	28 ^{-0.2} _{-0.6}	38	25	5	15	5.5	35	12	12	6.6	6.5
50	C5050	64	32 ^{-0.2} _{-0.6}	46.5	27	5	15	6.5	40	12	12	9	8.5
63	C5063	74	40 ^{-0.2} _{-0.6}	56.5	32	5	20	6.5	45	16	16	9	8.5
80	C5080	94	50 ^{-0.2} _{-0.6}	72	36	5	20	10	45	16	16	11	11
100	C5100	113	60 ^{-0.2} _{-0.6}	89	41	5	25	10	55	20	20	11	12
125	C5125	Max. 157	70 ^{-0.2} _{-0.6}	110	50	7	30	10	60	25	26	13.5	10

* Supplied with 4 mounting screws.

Dimensions: Mounting Brackets, Pivot Brackets for Cylinder Mounting

Double clevis (D)

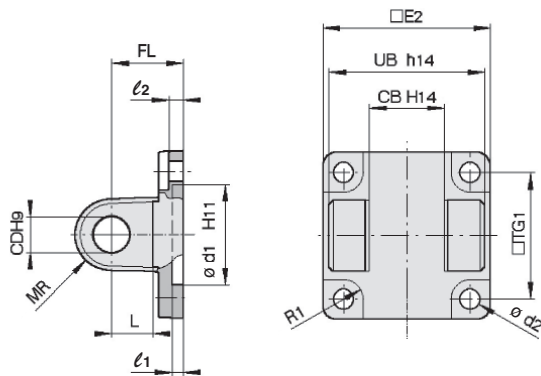

Bore size [mm]	Part no.	TG ₁	FL	l ₁	L	l ₂	ø d ₁	ø CD	MR	ø d ₂	R ₁	E ₂	UB	CB
32	D5032	32.5	22	5	12	5.5	30	10	9.5	6.6	6.5	48	45	26
40	D5040	38	25	5	15	5.5	35	12	12	6.6	6.5	56	52	28
50	D5050	46.5	27	5	15	6.5	40	12	12	9	8.5	64	60	32
63	D5063	56.5	32	5	20	6.5	45	16	16	9	8.5	75	70	40
80	D5080	72	36	5	20	10	45	16	16	11	11	95	90	50
100	D5100	89	41	5	25	10	55	20	20	11	12	115	110	60
125	D5125	110	50	—	30	10	60	25	25	13.5	—	Max.157	130	70

* Supplied with 4 mounting screws, clevis pin, and clevis pin bracket.

Clevis pivot bracket (E)

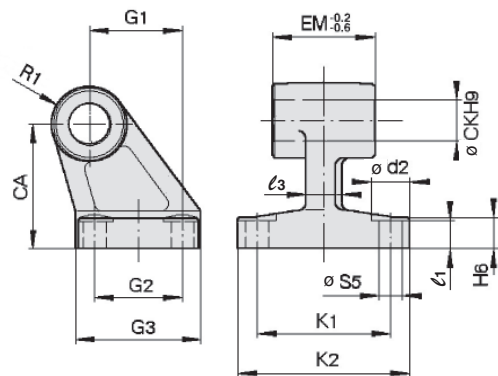

Bore size [mm]	Part no.	ø d ₂	ø CK	ø S5	K ₁	K ₂ (Max.)	l ₃ (Max.)	G ₁	l ₁	G ₂	EM	G ₃ (Max.)	CA	H ₆	R ₁
32	E5032	11	10	6.6	38	51	10	21	7	18	26 ^{-0.2} _{-0.6}	31	32	8	10
40	E5040	11	12	6.6	41	54	10	24	9	22	28 ^{-0.2} _{-0.6}	35	36	10	11
50	E5050	15	12	9	50	65	12	33	11	30	32 ^{-0.2} _{-0.6}	45	45	12	12
63	E5063	15	16	9	52	67	14	37	11	35	40 ^{-0.2} _{-0.6}	50	50	12	15
80	E5080	18	16	11	66	86	18	47	12.5	40	50 ^{-0.2} _{-0.6}	60	63	14	15
100	E5100	18	20	11	76	96	20	55	13.5	50	60 ^{-0.2} _{-0.6}	70	71	15	19
125	E5125	20	25	14	94	124	30	70	17	60	70 ^{-0.5} _{-1.5}	90	90	20	22.5

Single clevis with ball joint (CS)

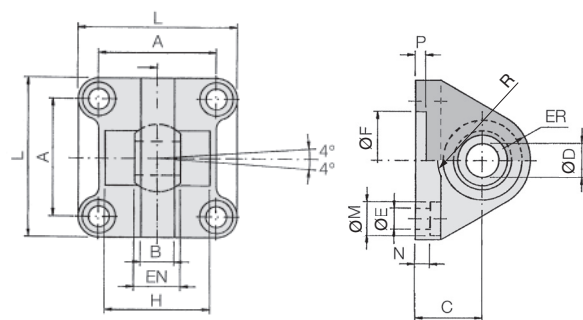

Bore size [mm]	Part no.	A	B (Max.)	C	ø DH7	EN ₀ ^{-0.1}	ER (Max.)	ø FH11	ø E	L	ø M	N	P	H ±0.5	R
32	CS5032	32.5	10.5	22	10	14	15	30	6.6	45	10.5	5.5	5	36	12.5
40	CS5040	38	12	25	12	16	18	35	6.6	55	11	5.5	5	42	14.5
50	CS5050	46.5	15	27	16	21	20	40	9	65	15	6.5	5	48	19.5
63	CS5063	56.5	15	32	16	21	23	45	9	75	15	6.5	5	55	19.5
80	CS5080	72	18	36	20	25	27	45	11	95	18	10	5	70	24.5
100	CS5100	89	18	41	20	25	30	55	11	115	18	10	5	80	24.5
125	CS5125	110	25	50	30	37	40	60	13.5	140	20	10	7	100	32.5

* Supplied with 4 mounting screws.

Series CP96

Dimensions: Pivot Brackets for Cylinder Mounting

Double clevis pivot bracket (DS)/for ES accessory

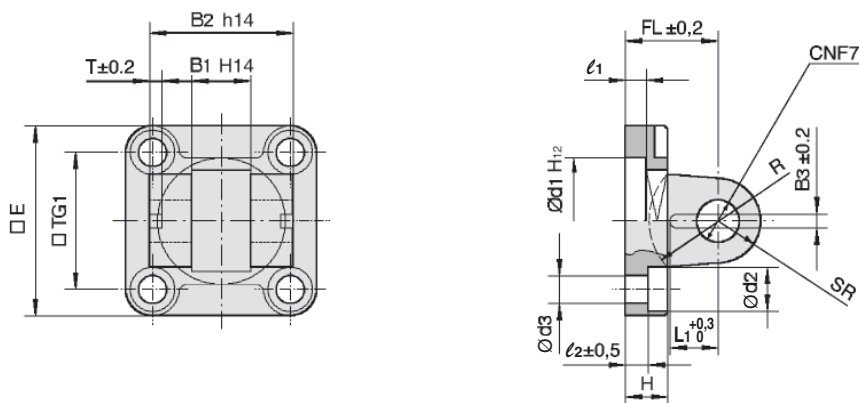

Bore size [mm]	Part no.	E	B ₁	B ₂	B ₃	L ₁	TG ₁	T	l ₁ (Min.)	l ₂	FL	H (Max.)	Ø d ₁	Ø d ₂	Ø d ₃	Ø CN	SR (Max.)	R
32	DS5032	45	14	34	3.3	11.5	32.5	3	5	5.5	22	10	30	10.5	6.6	10	11	17
40	DS5040	55	16	40	4.3	12	38	4	5	5.5	25	10	35	11	6.6	12	13	20
50	DS5050	65	21	45	4.3	14	46.5	4	5	6.5	27	12	40	15	9	16	18	22
63	DS5063	75	21	51	4.3	14	56.5	4	5	6.5	32	12	45	15	9	16	18	25
80	DS5080	95	25	65	4.3	16	72	4	5	10	36	16	45	18	11	20	22	30
100	DS5100	115	25	75	6.3	16	89	4	5	10	41	16	55	18	11	20	22	32
125	DS5125	140	37	97	6.3	24	110	6	7	10	50	20	60	20	13.5	30	30	42

* Supplied with 4 mounting screws, clevis pin, and clevis pin bracket.

Clevis pivot bracket with ball joint (ES)

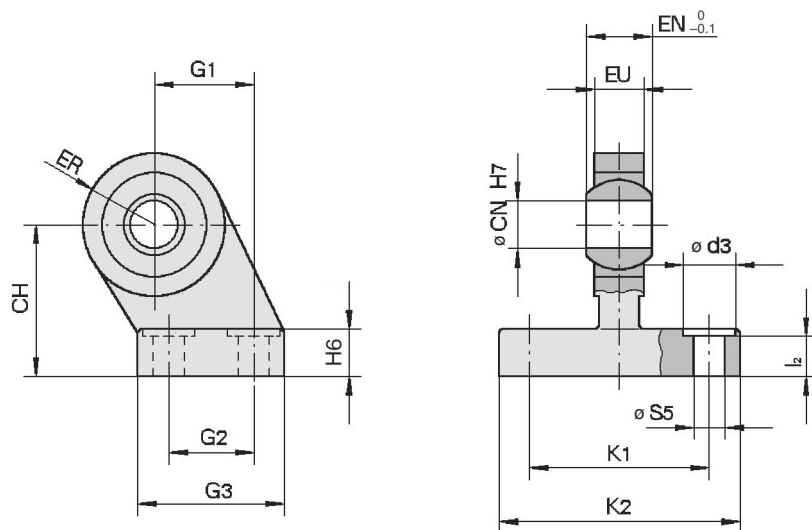

Bore size [mm]	Part no.	Ø d ₃	Ø CN	Ø S ₅	K ₁	K ₂ (Max.)	l ₂	G ₁	G ₂	G ₃ (Max.)	EN	EU	CH	H ₆	ER (Max.)
32	ES5032	11	10	6.6	38	51	8.5	21	18	31	14	10.5	32	10	15
40	ES5040	11	12	6.6	41	54	8.5	24	22	35	16	12	36	10	18
50	ES5050	15	16	9	50	65	10.5	33	30	45	21	15	45	12	20
63	ES5063	15	16	9	52	67	10.5	37	35	50	21	15	50	12	23
80	ES5080	18	20	11	66	86	11.5	47	40	60	25	18	63	14	27
100	ES5100	18	20	11	76	96	12.5	55	50	70	25	18	71	15	30
125	ES5125	20	30	13.5	94	124	17	70	60	90	37	25	90	20	40

Dimensions: Piston Rod Accessories

Floating joint: JA

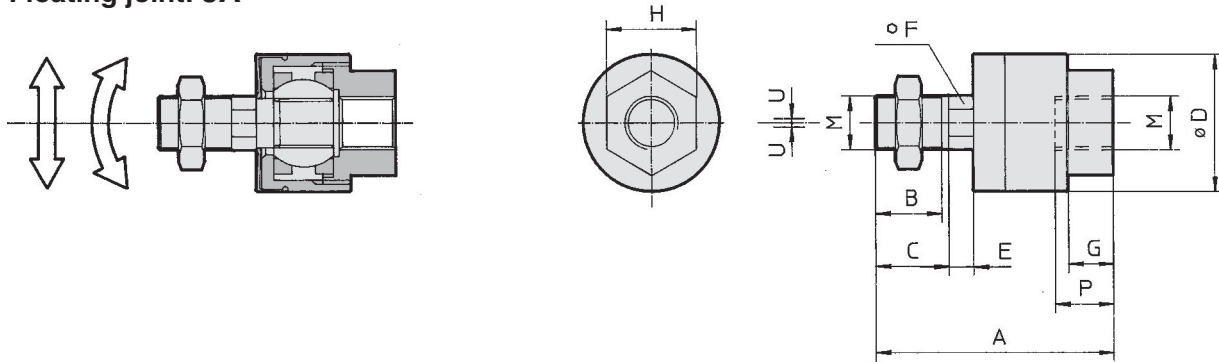

Bore size [mm]	Part no.	M	A	B	C	Ø D	E	F	G	H	P	U	Load [kN]	Weight [g]	Angle
32	JA30-10-125	M10 x 1.25	49.5	19.5	—	24	5	8	8	17	9	0.5	2.5	70	±0.5°
40	JA40-12-125	M12 x 1.25	60	20	—	31	6	11	11	22	13	0.75	4.4	160	
50, 63	JA50-16-150	M16 x 1.5	71.5	22	—	41	7.5	14	13.5	27	15	1	11	300	
80, 100	JAH50-20-150	M20 x 1.5	101	28	31	59.5	11.5	24	16	32	18	2	18	1080	
125	JA125-27-200	M27 x 2	123	34	38	66	13	27	20	41	24	2	28	1500	

* Black colour

Rod clevis: GKM (ISO 8140)

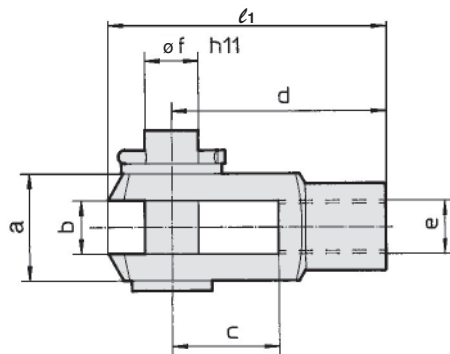

Bore size [mm]	Part no.	e	b	d	Ø f h11 (Shaft)	Ø f H9 (Hole)	l ₁	c (Min.)	a (Max.)
32	GKM10-20	M10 x 1.25	10 ^{+0.5} / _{+0.15}	40	10	10	52	20	20
40	GKM12-24	M12 x 1.25	12 ^{+0.5} / _{+0.15}	48	12	12	62	24	24
50, 63	GKM16-32	M16 x 1.5	16 ^{+0.5} / _{+0.15}	64	16	16	83	32	32
80, 100	GKM20-40	M20 x 1.5	20 ^{+0.5} / _{+0.15}	80	20	20	105	40	40
125	GKM30-54	M27 x 2	30 ^{+0.5} / _{+0.15}	110	30	30	148	54	55

* Supplied with clevis pin and clevis pin bracket.

Rod end: KJ (ISO 8139)

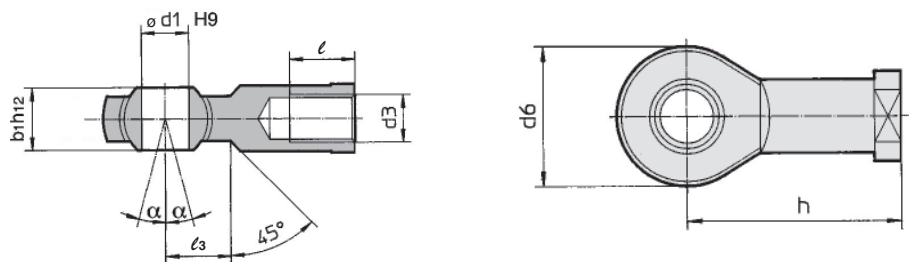

Bore size [mm]	Part no.	d ₃	Ø d ₁ H ₉	h	d ₆ (Max.)	b ₁ h ₁₂	l (Min.)	α	l ₃
32	KJ10D	M10 x 1.25	10	43	28	14	20	4°	15
40	KJ12D	M12 x 1.25	12	50	32	16	22	4°	17
50, 63	KJ16D	M16 x 1.5	16	64	42	21	28	4°	23
80, 100	KJ20D	M20 x 1.5	20	77	50	25	33	4°	27
125	KJ27D	M27 x 2	30	110	70	37	51	4°	36

ISO (15552) Standard

Air Cylinder: Non-rotating Rod Type Double Acting, Single/Double Rod

Series CP96K

Ø 32, Ø 40, Ø 50, Ø 63, Ø 80, Ø 100

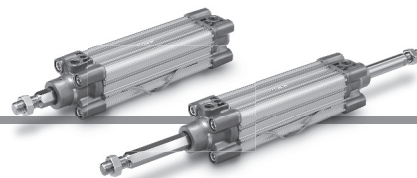

How to Order

CP96K **B** **32** - **100** **C** **W**

With auto switch **CP96KD** **B** **32** - **100** **C** **W** - **M9BW** **S**

With auto switch
(Built-in magnet)

Mounting

B	Basic
L	Axial foot
F	Rod flange
G	Head flange
C	Single clevis
D	Double clevis

* Mounting brackets are shipped together, (but not assembled).

Bore size

32	32 mm
40	40 mm
50	50 mm
63	63 mm
80	80 mm
100	100 mm

Number of auto switches

—	2 pcs.
S	1 pc.
3	3 pcs.
n	"n" pcs.

Auto switch

—	Without auto switch
---	---------------------

* For applicable auto switches, refer to the table below.

Rod

—	Single rod
W	Double rod

Air cushion on both ends + Bumper cushion

Cylinder stroke [mm]
Refer to "Maximum Strokes" on page 16.

Applicable Auto Switches/Tie-rod mounting

Type	Special function	Electrical entry	Indicator light	Wiring (Output)	Load voltage		Auto switch model	Lead wire length [m]				Pre-wired connector	Applicable load		
					DC	AC		0.5 (—)	1 (M)	3 (L)	5 (Z)				
Solid state auto switch	—	Grommet	No	3-wire (NPN)	24 V	5 V, 12 V	—	M9N	●	●	●	○	○	IC circuit	Relay, PLC
				3-wire (PNP)				M9P	●	●	●	○	○		
				2-wire				M9B	●	●	●	○	○		
				3-wire (NPN)				M9NW	●	●	●	○	○		
	Diagnostic indication (2-colour indication)	Grommet	Yes	3-wire (PNP)	24 V	5 V, 12 V	—	M9PW	●	●	●	○	○	IC circuit	Relay, PLC
				2-wire				M9BW	●	●	●	○	○		
				3-wire (NPN)				M9NA*1	○	○	●	○	○		
				3-wire (PNP)				M9PA*1	○	○	●	○	○		
				2-wire				M9BA*1	○	○	●	○	○		
				Water resistant (2-colour indication)											
Reed auto switch	—	Grommet	Yes	3-wire (NPN equivalent)	24 V	5 V	100 V or less	A96	●	—	●	—	—	IC circuit	—
				2-wire				A93	●	●	●	●	—		
								A90	●	—	●	—	—		

*1 Water resistant type auto switches can be mounted on the above models, but in such case SMC cannot guarantee water resistance. Please contact SMC regarding water resistant types with the above model numbers.

* Lead wire length symbols: 0.5 m — (Example) M9NW
1 m M (Example) M9NWM
3 m L (Example) M9NWL
5 m Z (Example) M9NWX

* Solid state auto switches marked with "○" are produced upon receipt of order.

* Since there are other applicable auto switches than listed above, refer to Auto Switch Guide for details.

* For details about auto switches with pre-wired connector, refer to Auto Switch Guide.

* The D-A9□/M9□/M9□W/M9□AL auto switches are shipped together, (but not assembled). (However, only the auto switch mounting brackets are assembled before shipment.)

Note) The D-Y59A, Y69A, Y7P, Y7□W, Z7□, Z80 cannot be mounted on the CP96 series.

Moreover, the D-M9□□ and A9□ auto switches cannot be mounted on square groove of the CP96 series.

Specifications

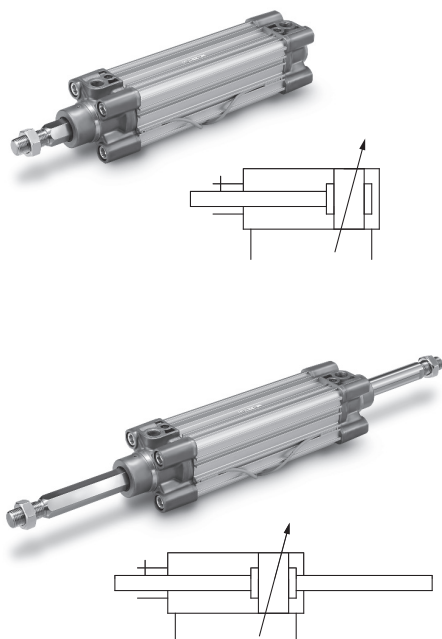

Bore size [mm]	32	40	50	63	80	100
Action	Double acting					
Fluid	Air					
Proof pressure	1.5 MPa					
Maximum operating pressure	1.0 MPa					
Minimum operating pressure	0.05 MPa					
Ambient and fluid temperature	Without auto switch: -20 to 70 °C (No freezing) With auto switch: -10 to 60 °C (No freezing)					
Lubrication	Not required (Non-lube)					
Operating piston speed	50 to 1000 mm/s					
Allowable stroke tolerance	Up to 500 stroke: $+2_0$, 501 to 1000 stroke: $+2.4_0$					
Cushion	Air cushion on both ends + Bumper cushion					
Port size	G 1/8	G 1/4	G 1/4	G 3/8	G 3/8	G 1/2
Mounting	Basic, Axial foot, Rod flange, Head flange, Single clevis, Double clevis					
Non-rotating accuracy	±0.5°		±0.5°		±0.3°	
Allowable rotational torque [N·m]	0.25	0.45	0.64	0.79		

Maximum Strokes

Bore size [mm]	Maximum stroke*
32	500
40	500
50	600
63	600
80	800
100	800

Intermediate strokes are available.

* Please consult with SMC for longer strokes.

Accessories

Mounting		Basic	Foot	Rod flange	Head flange	Single clevis	Double clevis
Standard	Rod end nut	●	●	●	●	●	●
	Clevis pin	—	—	—	—	—	●
Option	Rod end	●	●	●	●	●	●
	Rod clevis	●	●	●	●	●	●
	Rod boot	—	—	—	—	—	—

* Do not use a rod end (or floating joint) together with a single clevis with a ball joint (or clevis pivot bracket with a ball joint).

* Refer to pages 11 to 14 for dimensions and part numbers of the accessories.

⚠ Precautions

Be sure to read this before handling. Refer to the back cover for Safety Instructions. For Actuator and Auto Switch Precautions, refer to "Handling Precautions for SMC Products" and the Operation Manual on SMC website, <http://www.smc.eu>

Refer to pages 19 and 20 for cylinders with auto switches.

- Auto switch proper mounting position (detection at stroke end)
- Minimum stroke for auto switch mounting
- Operating range
- How to mount and move the auto switch

Series CP96K

Construction

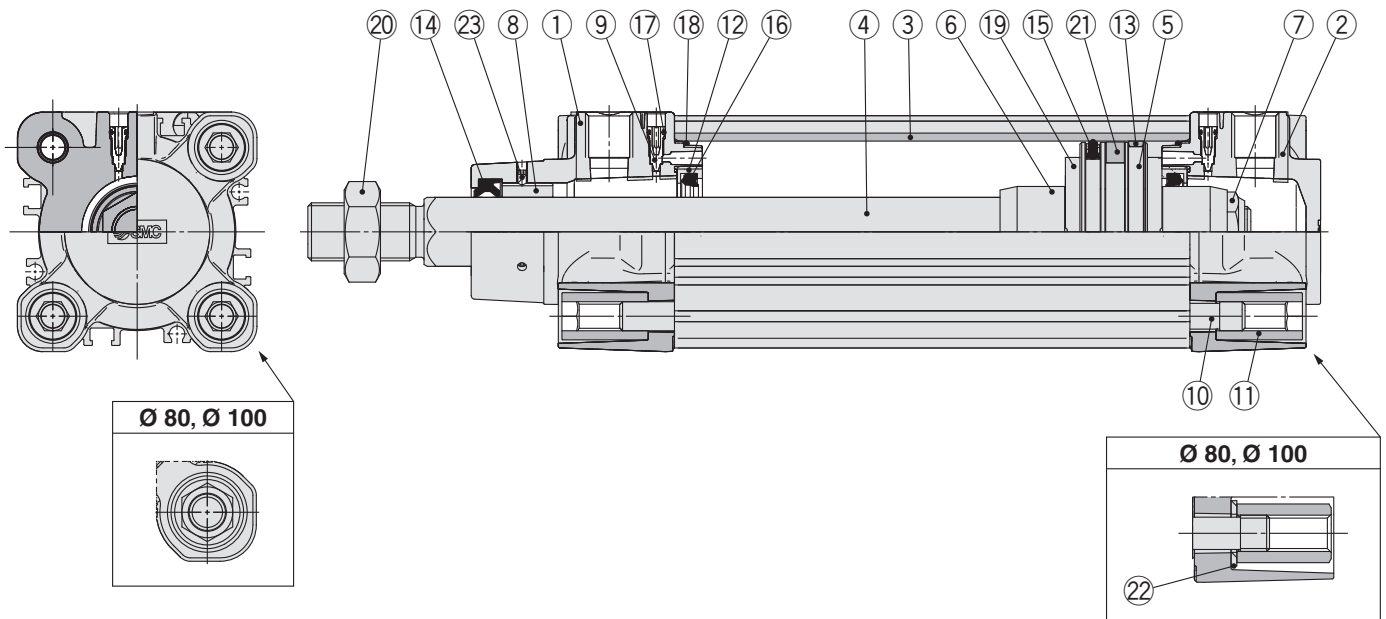

Component Parts

No.	Description	Material	Q'ty	Note
1	Rod cover	Aluminium die-cast	1	Trivalent chromated
2	Head cover	Aluminium die-cast	1	Trivalent chromated
3	Cylinder tube	Aluminium alloy	1	Hard anodised
4	Piston rod	Stainless steel	1	
5	Piston	Aluminium alloy	1	
6	Cushion ring	Rolled steel	2	Trivalent zinc chromated
7	Piston nut	Rolled steel	1	Trivalent zinc chromated
8	Non-rotating guide	Bearing alloy	1	
9	Cushion valve	Resin	2	
10	Tie-rod	Carbon steel	4	Trivalent zinc chromated
11	Tie-rod nut	Rolled steel	8	Trivalent zinc chromated
12	Cushion seal holder	Aluminium alloy	2	Anodised
13	Wear ring	Resin	1	
14	Rod seal	NBR	1	
15	Piston seal	NBR	1	
16	Cushion seal	Urethane	2	
17	Cushion valve seal	NBR	2	
18	Cylinder tube gasket	NBR	2	
19	Bumper	Urethane	2	
20	Rod end nut	Rolled steel	1	Trivalent zinc chromated
21	Magnet	—	(1)	
22	Flat washer	Steel	8	For Ø 80, Ø 100
23	Hexagon socket head set screw	Steel wire	2	Trivalent black zinc chromated

Replacement Parts/Seal Kit (Single rod)

Bore size [mm]	Kit no.	Contents
32	CK95-32	Kits include items ⑬ to ⑰, ⑱.
40	CK95-40	
50	CK95-50	
63	CK95-63	
80	CK95-80	
100	CK96-100	

* Seal kits consist of items ⑬ to ⑰, ⑱ and can be ordered by using the seal kit number corresponding to each bore size.
 * The seal kit includes a grease pack (10 g for Ø 32 to Ø 50, 20 g for Ø 63 and Ø 80, 30 g for Ø 100).

Order with the following part number when only the grease pack is needed.

Grease pack part number: GR-S010 (10 g), GR-S-020 (20 g)

Seal Kit (Double rod)

Bore size [mm]	Kit no.	Contents
32	CK95W-32	Kits include items ⑭ to ⑰, ⑱.
40	CK95W-40	
50	CK95W-50	
63	CK95W-63	
80	CK95W-80	
100	CK96W-100	

* Seal kits consist of items ⑭ to ⑰, ⑱ and can be ordered by using the seal kit number corresponding to each bore size.

* The seal kit includes a grease pack (10 g for Ø 32 to Ø 50, 20 g for Ø 63 and Ø 80, 30 g for Ø 100).

Order with the following part number when only the grease pack is needed.

Grease pack part number: GR-S010 (10 g), GR-S-020 (20 g)

Dimensions (Without mounting bracket)

CP96K (D) B Bore size – Stroke **C**

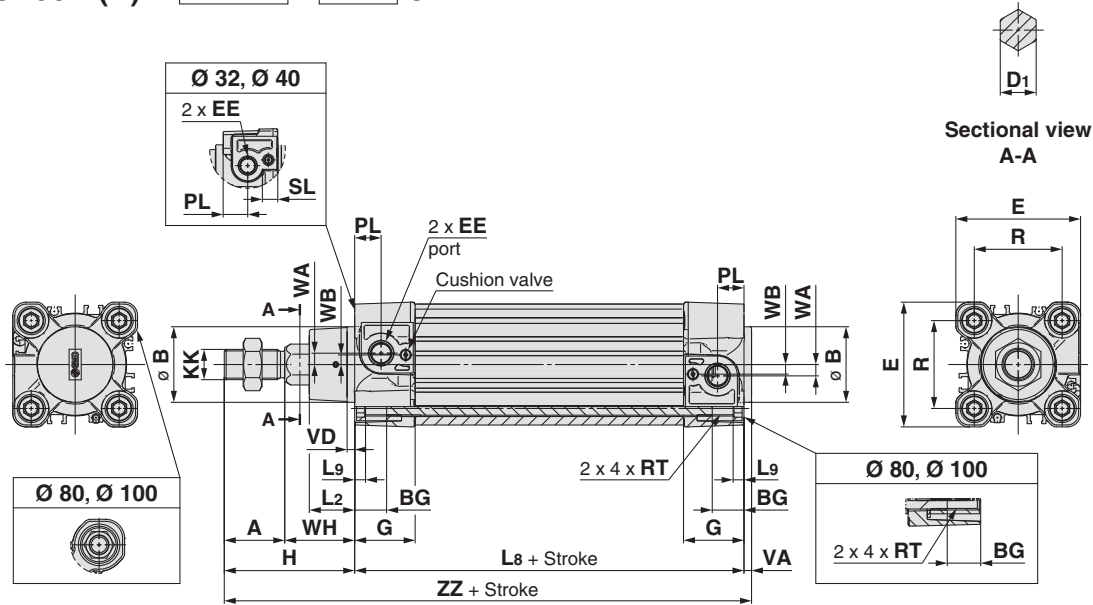

CP96K (D) B Bore size – Stroke **CW**

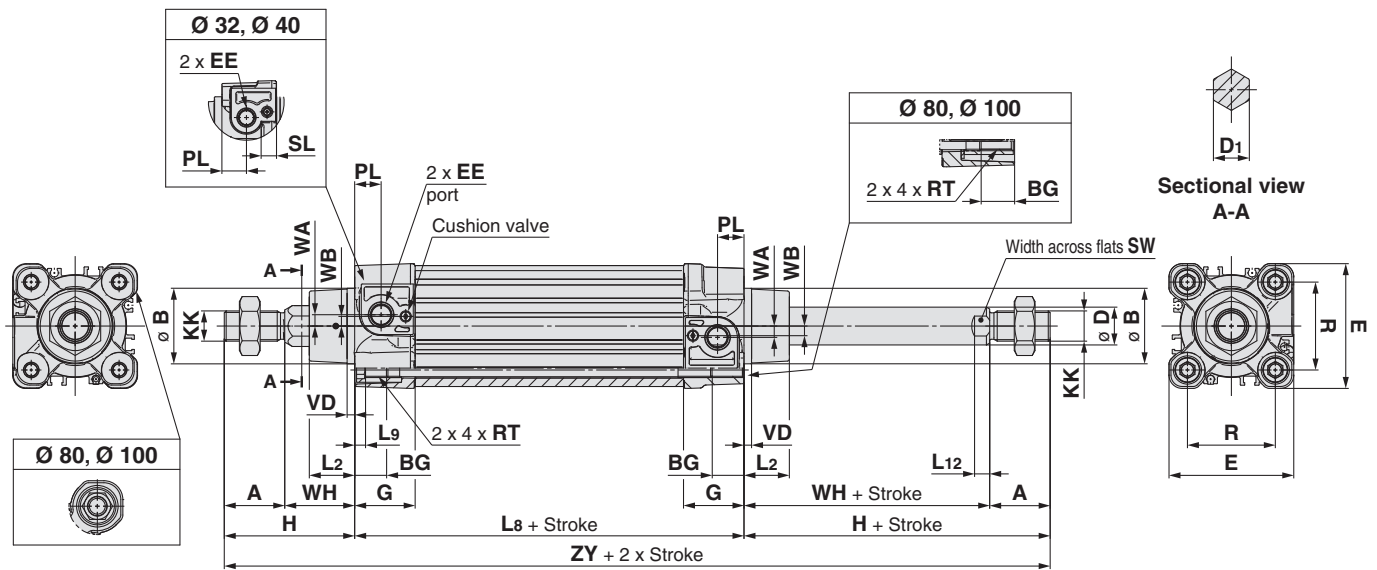

* Mounting brackets are the same as standard type. Refer to page 10 for details.

Bore size [mm]	Stroke range [mm]	A	Ø B d11	D1	Ø D	EE	PL	RT	L ₁₂	KK	SW	G	BG	L ₈	VD	VA	WA	WB	WH	ZZ	ZY	E	R	L ₂	L ₉	H	SL
32	Up to 500	22	30	12.2	12	G 1/8	13	M6 x 1	6	M10 x 1.25	10	28.9	16	94	4	4	4	7	26	146	190	47	32.5	15	4	48	8
40	Up to 500	24	35	14.2	16	G 1/4	14	M6 x 1	6.5	M12 x 1.25	13	32.6	16	105	4	4	5	8.9	30	163	213	54	38	17	4	54	8
50	Up to 600	32	40	19	20	G 1/4	14	M8 x 1.25	8	M16 x 1.5	17	32	16	106	4	4	6	5.1	37	179	244	66	46.5	24	5	69	—
63	Up to 600	32	45	19	20	G 3/8	16	M8 x 1.25	8	M16 x 1.5	17	38.6	16	121	4	4	9	6.3	37	194	259	77	56.5	24	5	69	—
80	Up to 800	40	45	23	25	G 3/8	16	M10 x 1.5	10	M20 x 1.5	22	38.4	17	128	4	4	11.5	6	46	218	300	99	72	30	—	86	—
100	Up to 800	40	55	23	25	G 1/2	18	M10 x 1.5	10	M20 x 1.5	22	42.9	17	138	4	4	17	10	51	233	320	118	89	32	—	91	—

Series CP96 Auto Switch Mounting

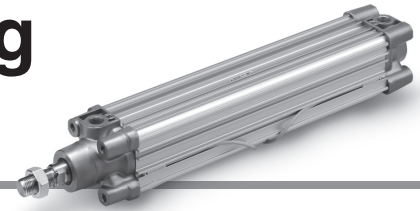

Auto Switch Proper Mounting Position (Detection at stroke end)

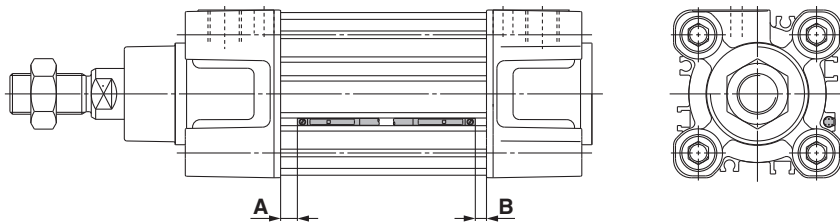

Auto Switch Proper Mounting Position [mm]

Auto switch model	D-M9□(V) D-M9□W(V) D-M9□A(V)		D-A9□(V)	
	A	B	A	B
Bore size				
32	14	10.5	10	6.5
40	14	14	10	10
50	15.5	14.5	11.5	10.5
63	16.5	15.5	12.5	11.5
80	21.5	18	17.5	14
100	21.5	19	17.5	15
125	16	16	12	12

Note 1) Adjust the auto switch after confirming the operating conditions in the actual setting.

Note 2) The D-M9□V/M9□WV/M9□AV/A9□V are mountable on Ø 32 to Ø 63.

Minimum Stroke for Auto Switch Mounting

Auto switch model	Number of auto switches	32	40	50	63	80	100	125
D-M9□ D-M9□W	With 2 pcs. (Same surface)	50						10
	With 1 pc./2 pcs. (Different surfaces)	10						10
	With n pcs.	10 + 40 (n - 2)						10 + 10 (n - 2)
D-M9□V D-M9□WV	With 2 pcs. (Same surface)	40						
	With 1 pc./2 pcs. (Different surfaces)	10						
	With n pcs.	10 + 30 (n - 2)						
D-M9□A	With 2 pcs. (Same surface)	55	50				10	
	With 1 pc./2 pcs. (Different surfaces)	15	10				10	
	With n pcs.	15 + 40 (n - 2)	10 + 40 (n - 2)				10 + 15 (n - 2)	
D-M9□AV	With 2 pcs. (Same surface)	40						
	With 1 pc./2 pcs. (Different surfaces)	10						
	With n pcs.	10 + 30 (n - 2)						
D-A9□	With 2 pcs. (Same surface)	50						15
	With 1 pc./2 pcs. (Different surfaces)	10						10
	With n pcs.	10 + 40 (n - 2)						15 + 20 (n - 2)
D-A9□V	With 2 pcs. (Same surface)	40						
	With 1 pc./2 pcs. (Different surfaces)	10						
	With n pcs.	10 + 30 (n - 2)						

Note 1) n = 3, 4, 5...

Note 2) The D-M9□V/M9□WV/M9□AV/A9□V are mountable on Ø 32 to Ø 63.

Operating Range

Auto switch model	Bore size						
	32	40	50	63	80	100	125
D-M9□(V) D-M9□W(V) D-M9□A(V)	4	4	5	6	5.5	6	7
D-A9□(V)	7	8	8.5	9.5	9.5	10.5	12.5

* Values which include hysteresis are for guideline purposes only, they are not a guarantee (assuming approximately ±30 % dispersion) and may change substantially depending on the ambient environment.

Note) The D-M9□V/M9□WV/M9□AV/A9□V are mountable on Ø 32 to Ø 63.

How to Mount and Move the Auto Switch

<Applicable Auto Switch>

Solid state switch **D-M9N(V)/M9P(V)/M9B(V)**
D-M9NW(V)/M9PW(V)/M9BW(V)
D-M9NA(V)/M9PA(V)/M9BA(V)

Reed switch..... **D-A90(V)/A93(V)/A96(V)**

How to Mount and Move the Auto Switch

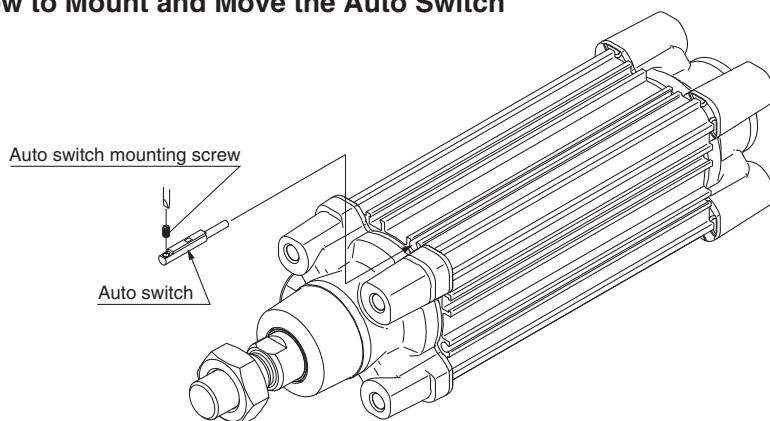

• Use a watchmaker's screwdriver with a handle diameter of 5 to 6 mm when tightening the auto switch mounting screw.

Auto switch mounting screw tightening torque [N·m]

Auto switch model	Tightening torque
D-M9□(V) D-M9□W(V) D-M9□A(V)	0.05 to 0.15
D-A9□(V)	0.10 to 0.20

* As a guide, turn 90° from the position where it comes to feel tight.

Note 1) The D-M9□ and A9□ cannot be mounted on square groove of the CP96 series.

Note 2) The D-M9□V/M9□WV/M9□AV/A9□V are mountable on Ø 32 to Ø 63.

Other than the applicable auto switches listed in “How to Order”, the following auto switches are mountable.

Refer to the **Auto Switch** Guide for the detailed specifications.

Type	Model	Electrical entry	Features	Applicable bore size
Solid state	D-M9NV, M9PV, M9BV	Grommet (Perpendicular)	—	Ø 32 to Ø 63
	D-M9NWV, M9PWV, M9B WV		Diagnostic indication (2-colour indication)	
	D-M9NAV, M9PAV, M9BAV		Water resistant (2-colour indication)	
Reed	D-A93V, A96V		—	
	D-A90V		Without indicator light	

* Normally closed (NC = b contact) solid state auto switches (D-F9G/F9H) are also available.

For details, refer to the **Auto Switch** Guide.

* With pre-wired connector is also available for solid state auto switches. For details, refer to the **Auto Switch** Guide.

Prior to Use

Auto Switch Connection and Example

Sink Input Specifications

3-wire, NPN

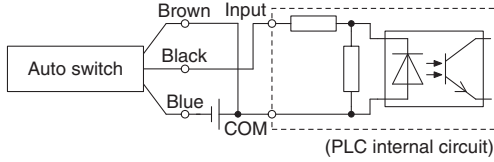

2-wire

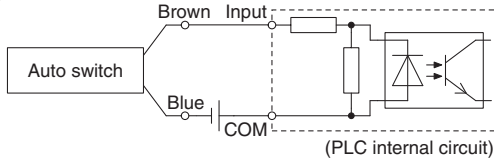

Source Input Specifications

3-wire, PNP

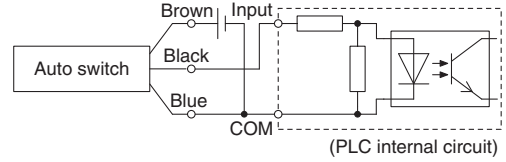

2-wire

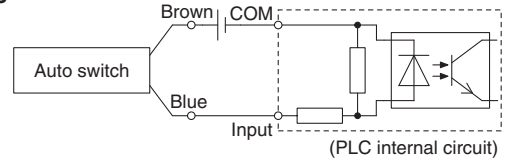

Connect according to the applicable PLC input specifications, as the connection method will vary depending on the PLC input specifications.

Example of AND (Series) and OR (Parallel) Connection

* When using solid state auto switches, ensure the application is set up so the signals for the first 50 ms are invalid.

3-wire AND connection for NPN output

(Using relays)

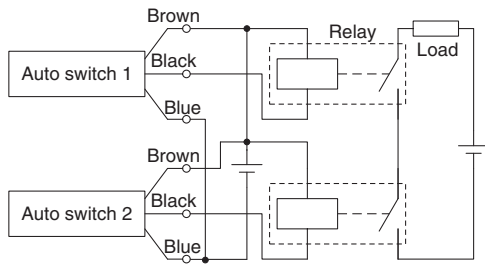

(Performed with auto switches only)

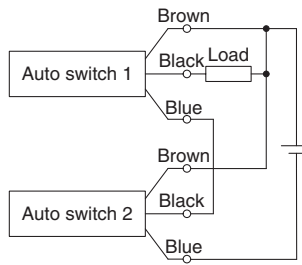

3-wire OR connection for NPN output

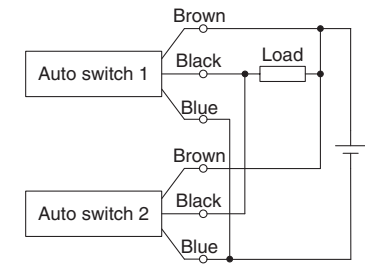

3-wire AND connection for PNP output

(Using relays)

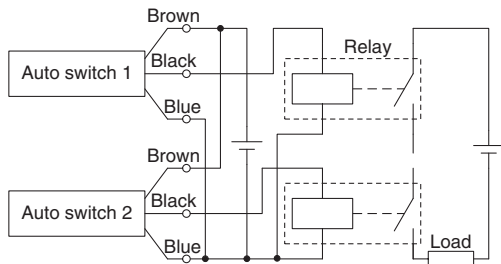

(Performed with auto switches only)

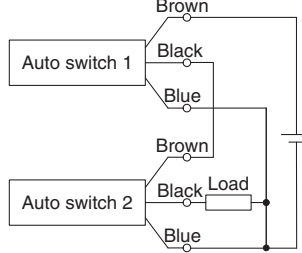

3-wire OR connection for PNP output

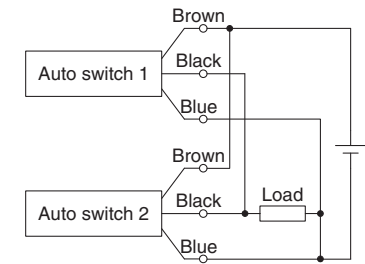

2-wire AND connection

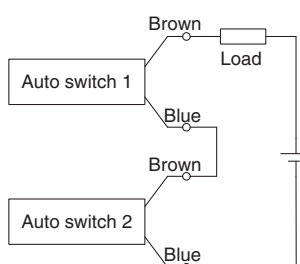

When two auto switches are connected in series, a load may malfunction because the load voltage will decline when in the ON state. The indicator lights will light up when both of the auto switches are in the ON state. Auto switches with load voltage less than 20 V cannot be used.

$$\begin{aligned} \text{Load voltage at ON} &= \text{Power supply voltage} - \\ &\quad \text{Residual voltage} \times 2 \text{ pcs.} \\ &= 24 \text{ V} - 4 \text{ V} \times 2 \text{ pcs.} \\ &= 16 \text{ V} \end{aligned}$$

Example: Power supply is 24 V DC
Internal voltage drop in auto switch is 4 V.

2-wire OR connection

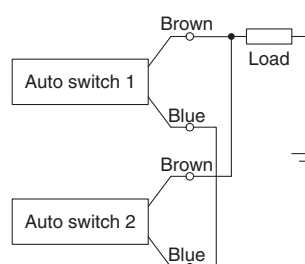

(Solid state)
When two auto switches are connected in parallel, malfunction may occur because the load voltage will increase when in the OFF state.

(Reed)
Because there is no current leakage, the load voltage will not increase when turned OFF. However, depending on the number of auto switches in the ON state, the indicator lights may sometimes grow dim or not light up, due to the dispersion and reduction of the current flowing to the auto switches.

$$\begin{aligned} \text{Load voltage at OFF} &= \text{Leakage current} \times 2 \text{ pcs.} \times \\ &\quad \text{Load impedance} \\ &= 1 \text{ mA} \times 2 \text{ pcs.} \times 3 \text{ k}\Omega \\ &= 6 \text{ V} \end{aligned}$$

Example: Load impedance is 3 k Ω .
Leakage current from auto switch is 1 mA.

Series CP96

Simple Specials/Made to Order



Please contact SMC for detailed specifications, delivery and prices.

Simple Specials

The following special specifications can be ordered as a simplified Made-to-Order.

Symbol	Specifications	CP96 (Standard type)	
		Double acting	
		Single rod	Double rod
-XA0 to 30	Change of rod end shape	<input checked="" type="checkbox"/>	<input checked="" type="checkbox"/>

Made to Order

Symbol	Specifications	CP96 (Standard type)	
		Double acting	
		Single rod	Double rod
-XB6	Heat resistant cylinder (-10 to 150 °C) <small>Note)</small>	<input checked="" type="checkbox"/>	<input checked="" type="checkbox"/>
-XC4	With heavy duty scraper	<input checked="" type="checkbox"/>	<input checked="" type="checkbox"/>
-XC7	Tie-rod, tie-rod nut, etc. made of stainless steel	<input checked="" type="checkbox"/>	<input checked="" type="checkbox"/>
-XC10	Dual stroke cylinder/Double rod type	<input checked="" type="checkbox"/>	<input checked="" type="checkbox"/>
-XC11	Dual stroke cylinder/Single rod type	<input checked="" type="checkbox"/>	<input checked="" type="checkbox"/>
-XC22	Fluororubber seal	<input checked="" type="checkbox"/>	<input checked="" type="checkbox"/>
-XC35	With coil scraper	<input checked="" type="checkbox"/>	<input checked="" type="checkbox"/>
-XC65	Made of stainless steel (Combination of -XC7 and -XC68)	<input checked="" type="checkbox"/>	<input checked="" type="checkbox"/>
-XC68	Made of stainless steel (with hard chrome plated piston rod)	<input checked="" type="checkbox"/>	<input checked="" type="checkbox"/>
-XC88	Spatter resistant coil scraper, Lube-retainer, grease for welding (Piston rod: Stainless steel 304)	<input checked="" type="checkbox"/>	<input checked="" type="checkbox"/>
-XC89	Spatter resistant coil scraper, Lube-retainer, grease for welding (Piston rod: S45C)	<input checked="" type="checkbox"/>	<input checked="" type="checkbox"/>

Note) The products with an auto switch are not compatible.

Series CP96 Simple Specials

These changes are dealt with Simple Specials System.

For details, refer to the Simple Specials System in our website.
<http://www.smc.eu>

1 Change of Rod End Shape

Symbol
-XA0 to -XA30

Applicable Series

Description	Model	Action	Symbol for change of rod end shape
Standard type	CP96S	Double acting, Single rod	XA0 to 30
	CP96S-W	Double acting, Double rod	XA0 to 30

⚠ Precautions

- SMC will make appropriate arrangements if no dimension, tolerance, or finish instructions are given in the diagram.
- Standard dimensions marked with "*" will be as follows to the rod diameter (D). Enter any special dimension you desire.
 $D \leq 6 \rightarrow D - 1 \text{ mm}$, $6 < D \leq 25 \rightarrow D - 2 \text{ mm}$, $D > 25 \rightarrow D - 4 \text{ mm}$
- In the case of double rod type and single acting retraction type, enter the dimensions when the rod is retracted.
- Only the single side of a double rod is able to manufacture.

Symbol: A0 	Symbol: A1 	Symbol: A2 	Symbol: A3 	Symbol: A4
Symbol: A5 	Symbol: A6 	Symbol: A7 	Symbol: A8 	Symbol: A9
Symbol: A10 	Symbol: A11 	Symbol: A12 	Symbol: A13 	Symbol: A14
Symbol: A15 	Symbol: A16 	Symbol: A17 	Symbol: A18 	Symbol: A19
Symbol: A20 	Symbol: A21 	Symbol: A22 	Symbol: A23 	Symbol: A24
Symbol: A25 	Symbol: A26 	Symbol: A27 	Symbol: A28 	Symbol: A29
Symbol: A30 				

Series CP96

Made to Order

Please contact SMC for detailed dimensions, specifications and lead times.



1 Heat Resistant Cylinder (−10 to 150 °C)

Symbol

-XB6

Air cylinder which changed the seal material and grease, so that it could be used even at higher temperature up to 150 °C.

Applicable Series

Description	Model	Action
Standard type	CP96S	Double acting, Single rod
	CP96S-W	Double acting, Double rod

How to Order

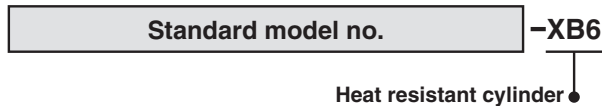

Specifications

Ambient temperature range	−10 to 150 °C
Seal material	Fluororubber
Grease	Heat resistant grease
Specifications other than above and external dimensions	Same as standard type

- Note 1) Operate without lubrication from a pneumatic system lubricator.
 Note 2) Please contact SMC for details on the maintenance intervals for this cylinder, which differ from those of the standard cylinder.
 Note 3) In principle, it is impossible to make built-in magnet type and the one with auto switch.
 But, as for the one with auto switch, and the heat resistant cylinder with heat resistant auto switch, since it will be differed depending on the series, please contact SMC.
 Note 4) Piston speed is ranged from 50 to 500 mm/s.

Warning

Precautions

Be aware that smoking cigarettes etc. after your hands have come into contact with the grease used in this cylinder can create a gas that is hazardous to humans.

2 With Heavy Duty Scraper

Symbol

-XC4

It is suitable for using cylinders under the environment, where there are much dusts in a surrounding area by using a heavy duty scraper on the wiper ring, or using cylinders under earth and sand exposed to the die-casted equipment, construction machinery, or industrial vehicles.

Applicable Series

Description	Model	Action	Nota
Standard type	CP96S	Double acting, Single rod	Ø 32 to Ø 100
	CP96S-W	Double acting, Double rod	Ø 32 to Ø 100

How to Order

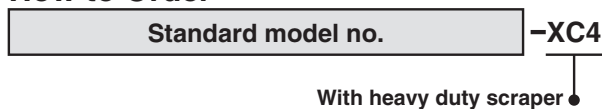

Specifications: Same as standard type

Dimensions: Same as standard type

Caution

Do not replace heavy duty scrapers.

Since heavy duty scrapers are press-fit, do not replace the cover only, but rather the entire rod cover assembly.

Series CP96

3 Tie-rod, Tie-rod Nut, etc. Made of Stainless Steel

Symbol
-XC7

When using in locations where the rust generation or corrosion likelihood exists, the standard parts material have been partly changed to the stainless steel.

Applicable Series

Description	Model	Action
Standard type	CP96S	Double acting, Single rod
	CP96S-W	Double acting, Double rod

How to Order

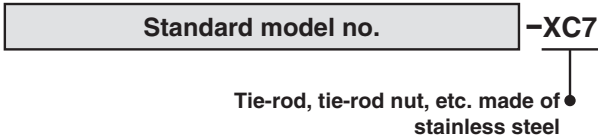

Specifications

Parts changed to stainless steel	Tie-rod, Tie-rod nut, Mounting bracket nut, Spring washer, Lock nut
Specifications other than above	Same as standard type
Dimensions	Same as standard type

4 Dual Stroke Cylinder/Double Rod Type

Symbol
-XC10

Two cylinders are constructed as one cylinder in a back-to-back configuration allowing the cylinder stroke to be controlled in three steps.

Applicable Series

Description	Model	Action	Note
Standard type	CP96S	Double acting, Single rod	Except clevis type

How to Order

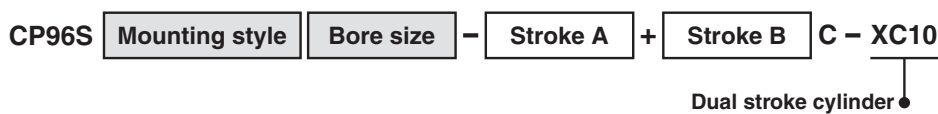

Specifications

Maximum manufacturable stroke [mm]	1000
------------------------------------	------

Function

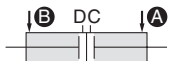

When air pressure is supplied to ports **A** and **B**, both strokes A and B retract.

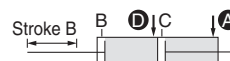

When air pressure is supplied to ports **A** and **D**, B out strokes.

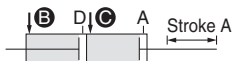

When air pressure is supplied to ports **B** and **C**, A out strokes.



When air pressure is supplied to ports **C** and **D**, both strokes A and B out strokes.

Dimensions (Dimensions other than below are the same as standard type.)

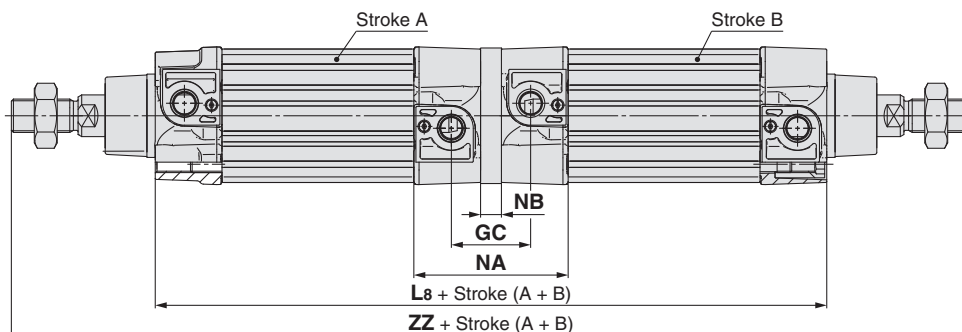

Bore size [mm]	L8	ZZ	NA	NB	GC
Ø 32	198	294	67.8	10	36
Ø 40	220	328	75.2	10	38
Ø 50	222	360	74	10	38
Ø 63	252	390	87.2	10	42
Ø 80	270	442	90.8	14	46
Ø 100	290	472	99.8	14	50

Symbol
-XC11

5 Dual Stroke Cylinder/Single Rod Type

Two cylinders can be integrated by connecting them in line, and the cylinder stroke can be controlled in two stages in both directions.

Applicable Series

Description	Model	Action
Standard type	CP96S	Double acting, Single rod

How to Order

Specifications: Same as standard type

CP96S Mounting style Bore size - Stroke A + Stroke B-A C - XC11
Dual stroke cylinder/Single rod type

Function

Functional description of dual stroke cylinder

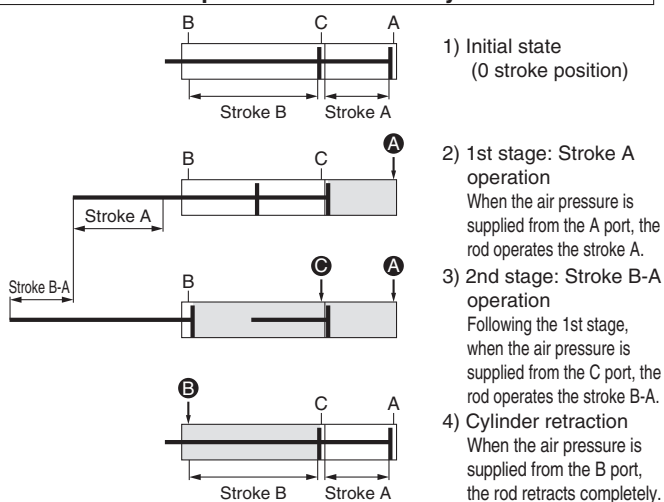

Stroke A or Stroke B operation can be made individually.

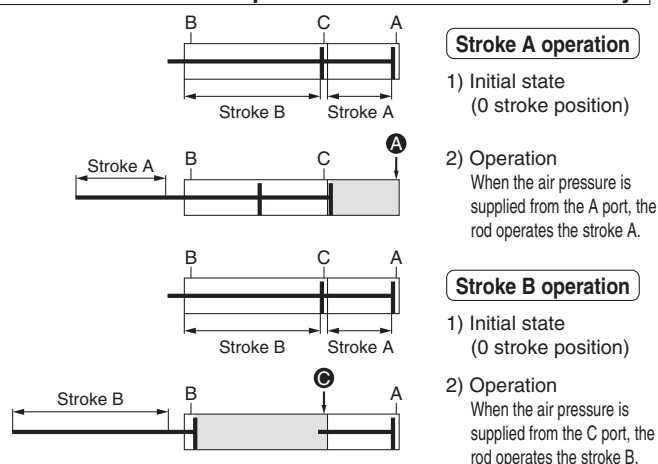

Double output is possible.

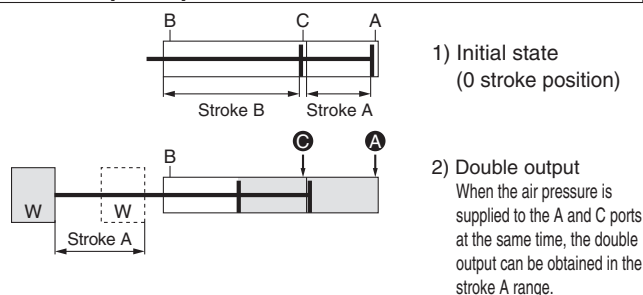

Precautions

⚠ Caution

- Do not supply air until the cylinder is fixed with the attached bolt.
- If air is supplied without securing the cylinder, the cylinder could lurch, posing the risk of bodily injury or damage to the peripheral equipment.

Dimensions (Dimensions other than below are the same as standard type.)

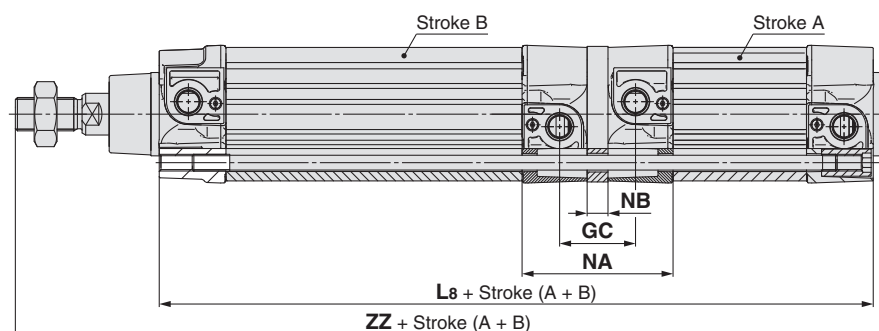

Bore size [mm]	L8	ZZ	NA	NB	GC
Ø 32	199	251	67.2	10	35.4
Ø 40	221	279	74.6	10	37.4
Ø 50	223	296	73.4	10	37.4
Ø 63	253	326	86.6	10	41.4
Ø 80	271	361	90.2	14	45.4
Ø 100	291	386	99.2	14	49.4

6 Fluororubber Seal

-XC22

Applicable Series

Description	Model	Action
Standard type	CP96S	Double acting, Single rod
	CP96S-W	Double acting, Double rod

How to Order

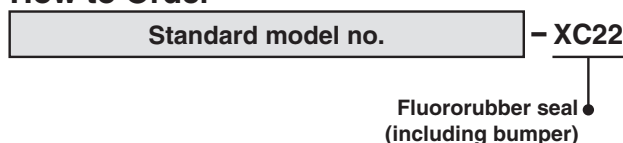

Specifications

Seal material	Fluororubber
Ambient temperature range	With auto switch: -10 °C to 60 °C (No freezing) ^{Note 1)} Without auto switch: -10 °C to 70 °C (No freezing)
Specifications other than above and external dimensions	Same as standard type

Note 1) Please contact SMC, as the type of chemical and the operating temperature may not allow the use of this product.

Note 2) Cylinders with auto switches can also be produced; however, auto switch related parts (auto switch units, mounting brackets, built-in magnets) are the same as standard products. Before using these, please contact SMC regarding their suitability for the operating environment.

7 With Coil Scraper

-XC35

It gets rid of frost, ice, weld spatter, cutting chips adhered to the piston rod, and protects the seals etc.

Applicable Series

Description	Model	Action
Standard type	CP96S	Double acting, Single rod
	CP96S-W	Double acting, Double rod

How to Order

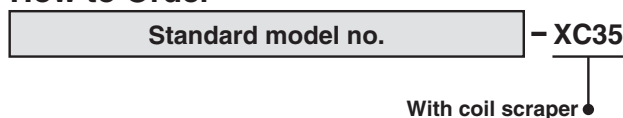

Specifications: Same as standard type

Dimensions: Same as standard type

8 Made of Stainless Steel (Combination of -XC7 and -XC68)

Symbol
-XC65

Suitable for the cases it is likely to generate rust by being immersed in the water and corrosion.

Applicable Series

Description	Model	Action
Standard type	CP96S	Double acting, Single rod
	CP96S-W	Double acting, Double rod

Note) There is a maximum stroke limit for CP96 cylinder.

Maximum Stroke [mm]

Double acting, Single rod	Double acting, Double rod
Ø 32: 1800 Ø 40 to Ø 100: 1700	1000 (Same as standard type)

Specifications

Parts changed to stainless steel	Piston rod, Rod end nut, Tie-rod, Tie-rod nut, Mounting bracket nut, Spring washer, Lock nut
Other specifications and external dimensions	Same as standard type

How to Order

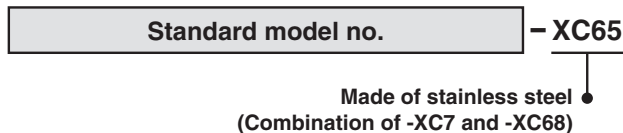

9 Made of Stainless Steel (With Hard Chrome Plated Piston Rod)

Symbol
-XC68

Suitable for the cases it is likely to generate rust by being immersed in the water and corrosion.

Applicable Series

Description	Model	Action
Standard type	CP96S	Double acting, Single rod
	CP96S-W	Double acting, Double rod

Maximum Stroke [mm]

Double acting, Single rod	Double acting, Double rod
Ø 32: 1800 Ø 40 to Ø 100: 1700	1000 (Same as standard type)

Specifications

Parts changed to stainless steel	Piston rod, Rod end nut
Other specifications and external dimensions	Same as standard type

How to Order

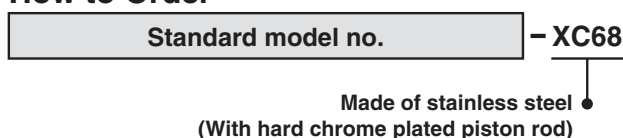

Series CP96

10 Spatter Resistant Coil Scraper, Lube-retainer, Grease for Welding (Piston rod: Stainless steel 304)

Symbol
-XC88

Reduces spatter adhesion and improves durability by the use of the coil scraper, Lube-retainer and grease for welding.

Applicable Series

Description	Model	Action	Note
Standard type	C96S	Double acting, Single rod	Except Ø 125
	C96S-W	Double acting, Double rod	

How to Order

Standard model no. **-XC88**

● Spatter resistant coil scraper, Lube-retainer, grease for welding (Piston rod: Stainless steel 304)

Specifications

Piston rod	Stainless steel 304 (With hard chrome plated)
Scraper	With coil scraper, With Lube-retainer
Grease	Grease for welding
Other specifications and external dimensions	Same as standard type

11 Spatter Resistant Coil Scraper, Lube-retainer, Grease for Welding (Piston rod: S45C)

Symbol
-XC89

Reduces spatter adhesion and improves durability by the use of the coil scraper, Lube-retainer and grease for welding.

Applicable Series

Description	Model	Action	Note
Standard type	C96S	Double acting, Single rod	Except Ø 125
	C96S-W	Double acting, Double rod	

How to Order

Standard model no. **-XC89**

● Spatter resistant coil scraper, Lube-retainer, grease for welding (Piston rod: S45C)

Specifications

Piston rod	S45C (With hard chrome plated)
Scraper	With coil scraper, With Lube-retainer
Grease	Grease for welding
Other specifications and external dimensions	Same as standard type



Series CP96

Specific Product Precautions

Be sure to read this before handling. Refer to the back cover for Safety Instructions. For Actuator and Auto Switch Precautions, refer to “Handling Precautions for SMC Products” and the Operation Manual on SMC website, <http://www.smc.eu>

Adjustment

Warning

1. Do not open the cushion valve more than the allowable number of rotations (following table).

Although the cushion valve is caulked as a retaining mechanism, do not open the cushion valve more than the allowable number of rotations. If air is supplied and operation started without confirming the above condition, the cushion valve may be ejected from the cover.

The allowable number of rotations refers to the number of rotations until the restrictor of the cushion valve is completely opened from the completely closed state.

2. Keep the screwing torque and the unscrewing torque of the cushion valve to the allowable torque or below (following table).

If a screwing torque or unscrewing torque beyond the allowable torque is applied, the valve will be damaged when the valve is closed completely or exceeds the retaining mechanism when the valve is opened completely, which will dislocate the engagement of the screw and eject the valve.

Bore size [mm]	Cushion valve width across flats	Hexagon wrench	Allowable number of rotations	Allowable torque [N·m]
32, 40	2	JIS 4648 Hexagon wrench key 2	4	0.02
50, 63	2	JIS 4648 Hexagon wrench key 2	4.5	0.02
80, 100	3	JIS 4648 Hexagon wrench key 3	5.5	0.06

3. Be certain to activate the air cushion at the stroke end.

When the air cushion is inactivated, if the allowable kinetic energy exceeds the value on page 5, the piston rod assembly or the tie-rod may be damaged. Set the air cushion to valid when operating the cylinder.



Caution

1. When replacing brackets, use the hexagon wrenches shown below.

Bore size [mm]	Width across flats	Tightening torque [N·m]
32, 40	4	4.8
50, 63	5	10.4
80, 100	6	18.2
125	10	28.5

Safety Instructions

These safety instructions are intended to prevent hazardous situations and/or equipment damage. These instructions indicate the level of potential hazard with the labels of “Caution,” “Warning” or “Danger.” They are all important notes for safety and must be followed in addition to International Standards (ISO/IEC)*1), and other safety regulations.

-  **Caution:** **Caution** indicates a hazard with a low level of risk which, if not avoided, could result in minor or moderate injury.
-  **Warning:** **Warning** indicates a hazard with a medium level of risk which, if not avoided, could result in death or serious injury.
-  **Danger:** **Danger** indicates a hazard with a high level of risk which, if not avoided, will result in death or serious injury.

- *1) ISO 4414: Pneumatic fluid power – General rules relating to systems.
- ISO 4413: Hydraulic fluid power – General rules relating to systems.
- IEC 60204-1: Safety of machinery – Electrical equipment of machines.
(Part 1: General requirements)
- ISO 10218-1: Manipulating industrial robots - Safety.
etc.

Warning

1. The compatibility of the product is the responsibility of the person who designs the equipment or decides its specifications.

Since the product specified here is used under various operating conditions, its compatibility with specific equipment must be decided by the person who designs the equipment or decides its specifications based on necessary analysis and test results. The expected performance and safety assurance of the equipment will be the responsibility of the person who has determined its compatibility with the product. This person should also continuously review all specifications of the product referring to its latest catalogue information, with a view to giving due consideration to any possibility of equipment failure when configuring the equipment.

2. Only personnel with appropriate training should operate machinery and equipment.

The product specified here may become unsafe if handled incorrectly. The assembly, operation and maintenance of machines or equipment including our products must be performed by an operator who is appropriately trained and experienced.

3. Do not service or attempt to remove product and machinery/equipment until safety is confirmed.

1. The inspection and maintenance of machinery/equipment should only be performed after measures to prevent falling or runaway of the driven objects have been confirmed.
2. When the product is to be removed, confirm that the safety measures as mentioned above are implemented and the power from any appropriate source is cut, and read and understand the specific product precautions of all relevant products carefully.
3. Before machinery/equipment is restarted, take measures to prevent unexpected operation and malfunction.

4. Contact SMC beforehand and take special consideration of safety measures if the product is to be used in any of the following conditions.

1. Conditions and environments outside of the given specifications, or use outdoors or in a place exposed to direct sunlight.
2. Installation on equipment in conjunction with atomic energy, railways, air navigation, space, shipping, vehicles, military, medical treatment, combustion and recreation, or equipment in contact with food and beverages, emergency stop circuits, clutch and brake circuits in press applications, safety equipment or other applications unsuitable for the standard specifications described in the product catalogue.
3. An application which could have negative effects on people, property, or animals requiring special safety analysis.
4. Use in an interlock circuit, which requires the provision of double interlock for possible failure by using a mechanical protective function, and periodical checks to confirm proper operation.

Limited warranty and Disclaimer/ Compliance Requirements

The product used is subject to the following “Limited warranty and Disclaimer” and “Compliance Requirements”.

Read and accept them before using the product.

Limited warranty and Disclaimer

1. The warranty period of the product is 1 year in service or 1.5 years after the product is delivered, whichever is first.*2) Also, the product may have specified durability, running distance or replacement parts. Please consult your nearest sales branch.
2. For any failure or damage reported within the warranty period which is clearly our responsibility, a replacement product or necessary parts will be provided. This limited warranty applies only to our product independently, and not to any other damage incurred due to the failure of the product.
3. Prior to using SMC products, please read and understand the warranty terms and disclaimers noted in the specified catalogue for the particular products.

*2) Vacuum pads are excluded from this 1 year warranty.

A vacuum pad is a consumable part, so it is warranted for a year after it is delivered. Also, even within the warranty period, the wear of a product due to the use of the vacuum pad or failure due to the deterioration of rubber material are not covered by the limited warranty.

Compliance Requirements

1. The use of SMC products with production equipment for the manufacture of weapons of mass destruction (WMD) or any other weapon is strictly prohibited.
2. The exports of SMC products or technology from one country to another are governed by the relevant security laws and regulations of the countries involved in the transaction. Prior to the shipment of a SMC product to another country, assure that all local rules governing that export are known and followed.

Caution

1. The product is provided for use in manufacturing industries.

The product herein described is basically provided for peaceful use in manufacturing industries.

If considering using the product in other industries, consult SMC beforehand and exchange specifications or a contract if necessary.

If anything is unclear, contact your nearest sales branch.

Caution

SMC products are not intended for use as instruments for legal metrology.

Measurement instruments that SMC manufactures or sells have not been qualified by type approval tests relevant to the metrology (measurement) laws of each country. Therefore, SMC products cannot be used for business or certification ordained by the metrology (measurement) laws of each country.

Safety Instructions

Be sure to read “Handling Precautions for SMC Products” (M-E03-3) before using.

SMC Corporation (Europe)

Austria	☎+43 (0)2262622800	www.smc.at	office@smc.at	Lithuania	☎+370 5 2308118	www.smc.lt	info@smc.lt
Belgium	☎+32 (0)33551464	www.smc-pneumatics.be	info@smc-pneumatics.be	Netherlands	☎+31 (0)205318888	www.smc-pneumatics.nl	info@smc-pneumatics.nl
Bulgaria	☎+359 (0)2807670	www.smc.bg	office@smc.bg	Norway	☎+47 67129020	www.smc-norge.no	post@smc-norge.no
Croatia	☎+385 (0)13707288	www.smc.hr	office@smc.hr	Poland	☎+48 222119600	www.smc.pl	office@smc.pl
Czech Republic	☎+420 541424611	www.smc.cz	office@smc.cz	Portugal	☎+351 226166570	www.smc.eu	postpt@smc.smces.es
Denmark	☎+45 70252900	www.smc-dk.com	smc@smc-dk.com	Romania	☎+40 213205111	www.smcromania.ro	smcromania@smcromania.ro
Estonia	☎+372 6510370	www.smc-pneumatics.ee	smc@smc-pneumatics.ee	Russia	☎+7 8127185445	www.smc-pneumatik.ru	info@smc-pneumatik.ru
Finland	☎+358 207513513	www.smc.fi	smc-fi@smc.fi	Slovakia	☎+421 (0)413213212	www.smc.sk	office@smc.sk
France	☎+33 (0)164761000	www.smc-france.fr	info@smc-france.fr	Slovenia	☎+386 (0)73885412	www.smc.si	office@smc.si
Germany	☎+49 (0)61034020	www.smc.de	info@smc.de	Spain	☎+34 902184100	www.smc.eu	post@smc.smces.es
Greece	☎+30 210 2717265	www.smc-hellas.gr	sales@smc-hellas.gr	Sweden	☎+46 (0)86031200	www.smc.nu	post@smc.nu
Hungary	☎+36 23513000	www.smc.hu	office@smc.hu	Switzerland	☎+41 (0)523963131	www.smc.ch	info@smc.ch
Ireland	☎+353 (0)14039000	www.smc-pneumatics.ie	sales@smc-pneumatics.ie	Turkey	☎+90 212 489 0 440	www.smc-pneumatik.com.tr	info@smc-pneumatik.com.tr
Italy	☎+39 0292711	www.smc-italia.it	mailbox@smc-italia.it	UK	☎+44 (0)845 121 5122	www.smc-pneumatics.co.uk	sales@smc-pneumatics.co.uk
Latvia	☎+371 67817700	www.smc-lv.lv	info@smc-lv.lv				

SMC CORPORATION Akihabara UDX 15F, 4-14-1, Sotokanda, Chiyoda-ku, Tokyo 101-0021, JAPAN Phone: 03-5207-8249 FAX: 03-5298-5362

1st printing WQ printing WP 00 Printed in Spain

Specifications are subject to change without prior notice and any obligation on the part of the manufacturer.