

# Precision Regulator

## Series *IR1000/2000/3000*



The addition of the small size Series IR1000 and the large size Series IR3000 provides an increased range of flow rates from approx. 200ℓ/min. to approx. 6000ℓ/min.

# Precision Regulator

## Series *IR1000/2000/3000*

### Bracket and pressure gauge can be mounted from 2 directions

Mounting is possible on either the front or the back

### Expanded regulating pressure range

The maximum set pressure has been expanded from the conventional 0.7MPa to 0.8MPa

### Compact and light weight

**IR1000** width 35mm weight 140g

(previously unavailable small size added)

**IR2000** width 50mm weight 300g

(▲ width 14%, weight ▲6% Compared to SMC IR200)

**IR3000** width 66mm weight 640g

(▲ width 21%, weight ▲36% Compared to SMC IR400)



2 air operated models

Air operated style added to series IR2000

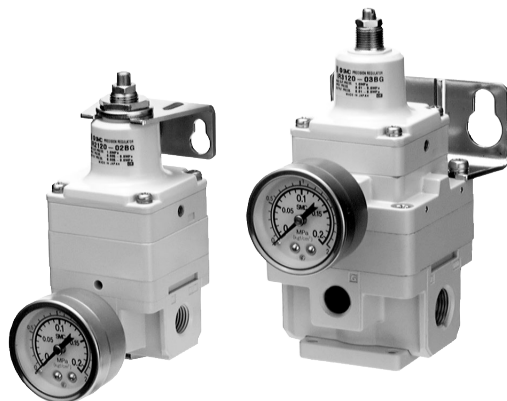

IR2120

IR3120

### Manifolding is possible

Made to order specifications (except series IR2120, IR3000)

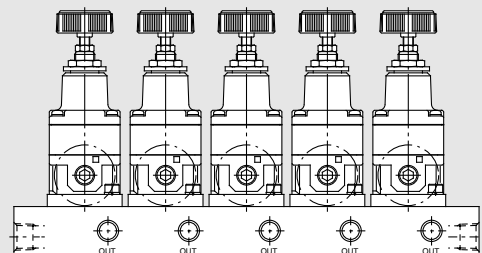

# Modular body introduced (-X120)

Can be combined with AF (air filter) and AFM (mist separator).

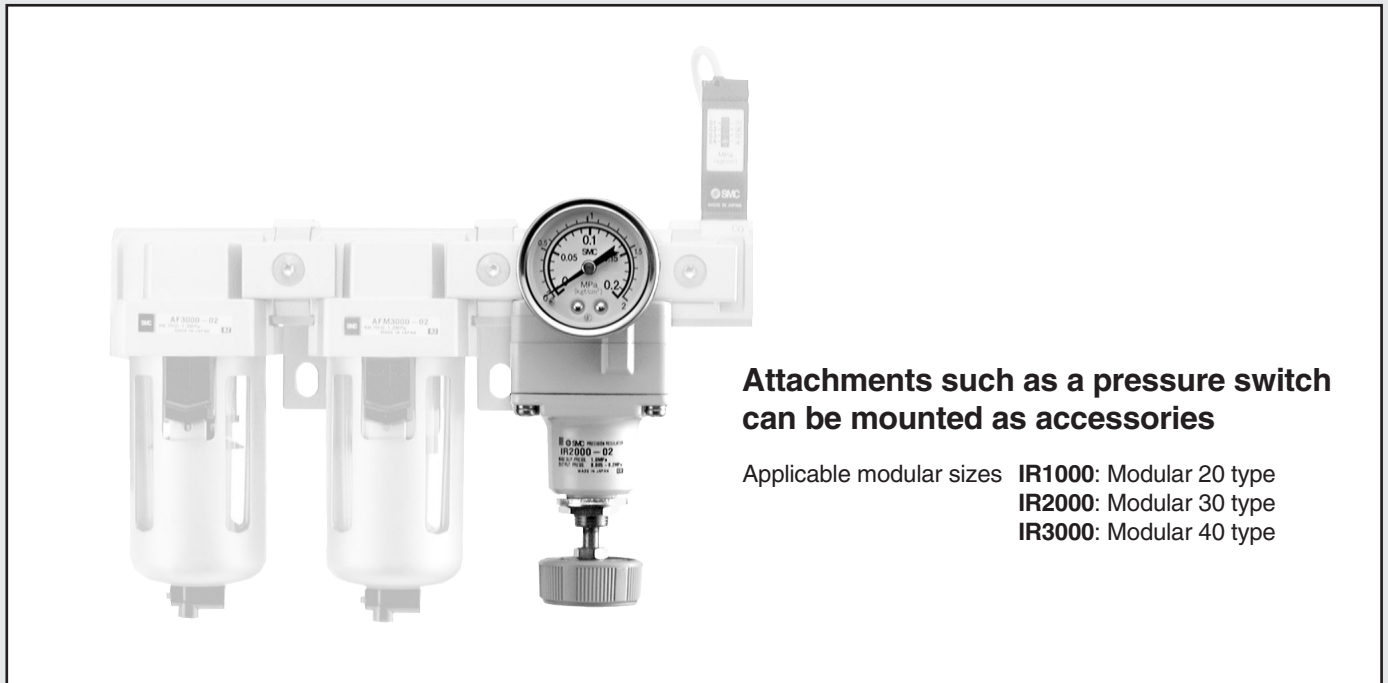

**Attachments such as a pressure switch can be mounted as accessories**

Applicable modular sizes **IR1000**: Modular 20 type  
**IR2000**: Modular 30 type  
**IR3000**: Modular 40 type

## Superior relief flow characteristics

Relief flow has been increased by nearly 5 times (compared to SMC IR201, IR401)

Conditions: Back pressure 0.7MPa

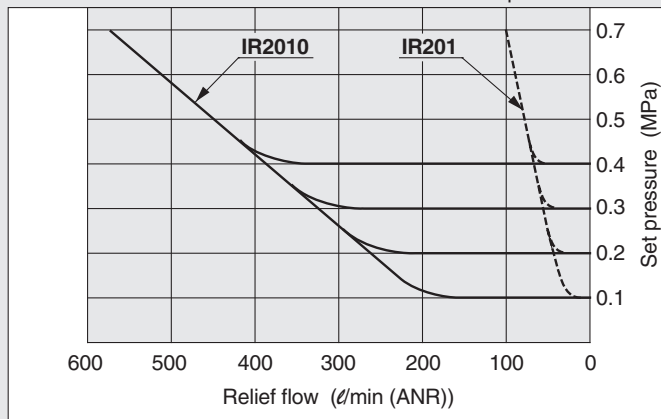

Conditions: Back pressure 0.7MPa

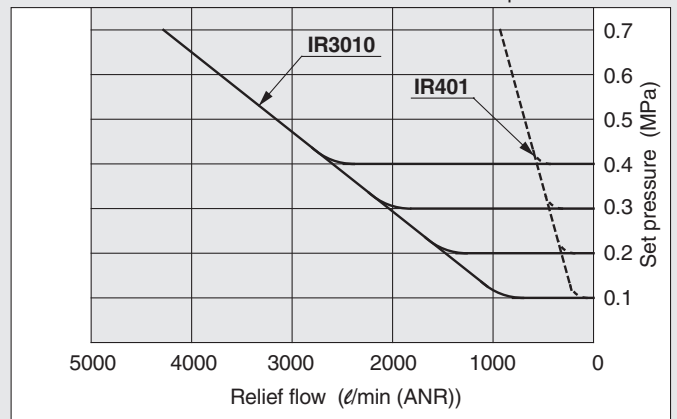

### Series Variations

Specifications	Model	Basic			Air operated	
		IR10□□	IR20□□	IR30□□	IR2120	IR3120
Maximum set pressure	0.2MPa	●	●	●	—	—
	0.4MPa	●	●	●	—	—
	0.8MPa	●	●	●	●	●
Port size	Rc(PT) 1/8	●	—	—	—	—
	Rc(PT) 1/4	—	●	●	●	●
	Rc(PT) 3/8	—	—	●	—	●
	Rc(PT) 1/2	—	—	●	—	●

● Available – Not available

### Made to Order Specifications

Symbol	Specifications/Content
10-	Clean room specifications
20-	Copper-free specifications
80-	Ozone resistant specifications
-T	For high temperature
-L	For low temperature
-X1	Non-grease specifications
-X465□	With digital pressure switch (ISE30)
IRM□□	Manifold (except series IR2120, IR3000)

# Application Examples

## Constant fluid pressure

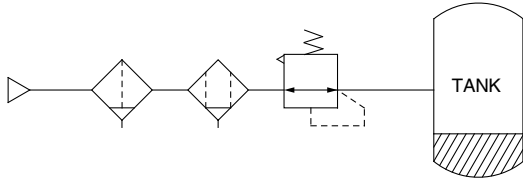

- Since there is a large effective area for supply and exhaust, pressure setting can be done quickly.

## Balance and drive Accurate balance pressure setting

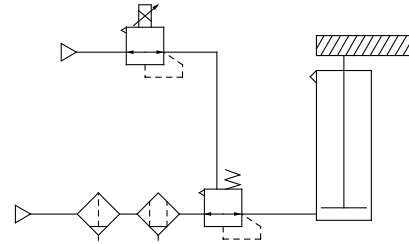

- Limits pressure fluctuation when driving a cylinder, maintaining excellent static and dynamic balance.

## Accurate pressure setting – Sensitivity within 0.2%F.S. (full span) Tension controller

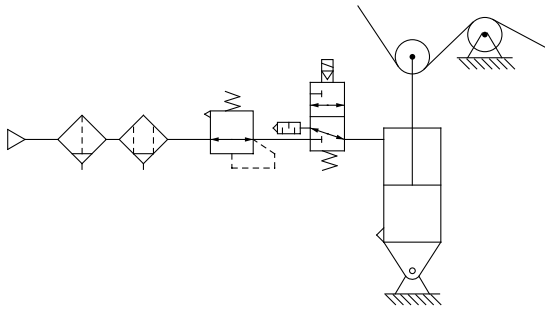

## Contact pressure control

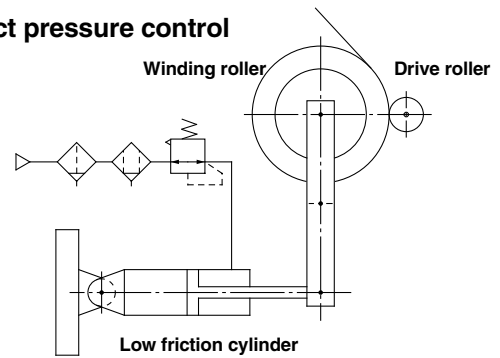

- Adapts to the cylinder's piston displacement, maintaining a constant pressure.

## Multistage control of work piece pressing force (Wrapping machine)

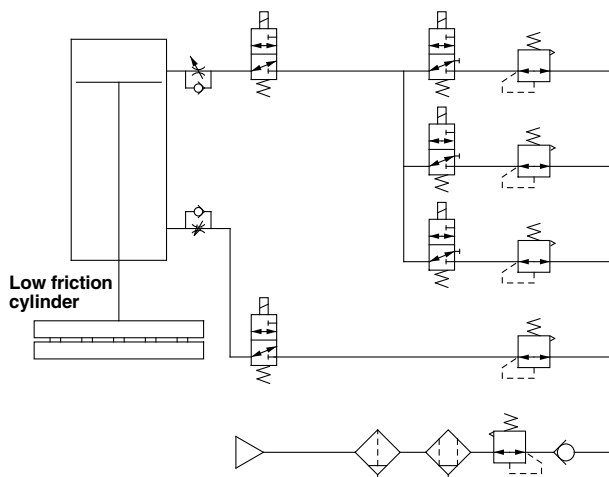

## Leak test circuit

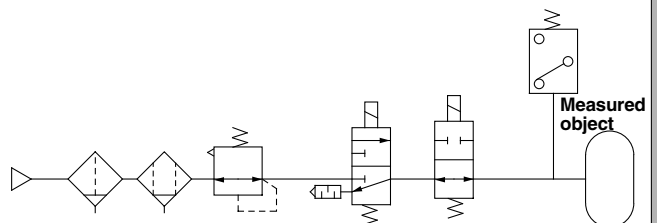

# Precision Regulator

## Series IR1000/2000/3000

JIS symbol

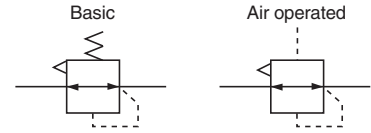

### Standard Specifications

Model	Basic style			Air operated style	
	IR10□0	IR20□0	IR30□0	IR2120	IR3120
Max. supply pressure	Maximum 1.0MPa				
Min. supply pressure	Set pressure+0.05MPa <sup>(1)</sup>			Set pressure+0.1MPa	Set pressure+0.1MPa
Set pressure range	IR1000: 0.005 to 0.2 MPa IR1010: 0.01 to 0.4 MPa IR1020: 0.01 to 0.8 MPa	IR2000: 0.005 to 0.2 MPa IR2010: 0.01 to 0.4 MPa IR2020: 0.01 to 0.8 MPa	IR3000: 0.01 to 0.2 MPa IR3010: 0.01 to 0.4 MPa IR3020: 0.01 to 0.8 MPa	0.01 to 0.8MPa	0.01 to 0.8MPa
Input signal pressure <sup>(2)</sup>	—			0.01 to 0.8MPa	0.01 to 0.8MPa
Sensitivity	Within 0.2% of full span				
Repeatability	Within 0.5% of full span				
Linearity <sup>(3)</sup>	—			Within 1% of full span	
Air consumption <sup>(4)</sup> (At supply pressure of 1.0 MPa)	4.4 ℓ/min (ANR) or less	4.4 ℓ/min (ANR) or less	11.5 ℓ/min (ANR) or less	4.4 ℓ/min (ANR) or less	11.5 ℓ/min (ANR) or less
Port size	Rc(PT) 1/8	Rc(PT) 1/4	Rc(PT) 1/4, 3/8, 1/2	Rc(PT) 1/4	Rc(PT) 1/4, 3/8, 1/2
Pressure gauge port	Rc(PT) 1/8 (2 locations)				
Ambient and fluid temperature	- 5 to 60°C (No freezing)				
Weight (kg)	0.14	0.30	0.64	0.35	0.71

Note 1) With the condition of no flow on the output side. Together with the set pressure, be sure to maintain a minimum differential pressure of 0.05MPa for models IR1000 and IR2000, and 0.1MPa for model IR3000.

Note 2) Applicable only to air operated styles IR2120 and IR3120. The basic style is excepted.

Note 3) Indicates the linearity of the output pressure with respect to the input signal pressure.

Note 4) Air is normally being discharged to the atmosphere.

### How to Order

**IR 2000-02**

**Precision regulator**

**Body size**

1	IR1000
2	IR2000
3	IR3000

**Type of setting**

0	Basic type (Handle)
1	Air operated type (Series IR2000/3000 only)

**Regulating pressure range**

**For series IR1000/2000**

0	0.005 to 0.2 MPa
1	0.01 to 0.4 MPa
2	0.01 to 0.8 MPa

Note) Air operated type is model IR2120 only.

**For series IR3000**

0	0.01 to 0.2 MPa
1	0.01 to 0.4 MPa
2	0.01 to 0.8 MPa

Note) Air operated type is model IR3120 only.

**Thread type**

—	Rc
N	NPT*
F	G*

\* Option

**Port size**

Symbol	size	Application		
		IR1000	IR2000	IR3000
01	1/8	●		
02	1/4		●	●
03	3/8			●
04	1/2			●

**Suffix 1**

—	Standard
T	For high temp. environments (-5 to 100°C) (Max. 80°C with pressure gauge.)
L	For low temp. environments (-30 to 60°C)

**Suffix 2**

—	None
Note) R	Pressure gauge, Bracket, Name plate, Mounting on the opposite side

Note) The standard mounting position of the pressure gauge is on the front, when viewing the regulator with the SUP side to the left and OUT side to the right.

**Accessory**

—	None
B	With bracket
G	With pressure gauge*

\* Pressure gauge is included, (but not assembled).

**Made to Order Specifications (Refer to page 8)**

Symbol	Specifications/Content
X1	Non-grease specifications
X120	Compatible with modular connection brackets(Refer to page 2)
X465□	With digital pressure switch (ISE30A)

\* 1 Add prefix (10-) for the clean room specification.

\* 2 Add prefix (20-) for the copper-free and fluorine-free specification.

\* 3 Add prefix (80-) for the ozone-resistant specification.

\* 4 Manifold specification is available for IR1000 and IR2000.

(Except IR2120 and IR3000)

# Series IR1000/2000/3000

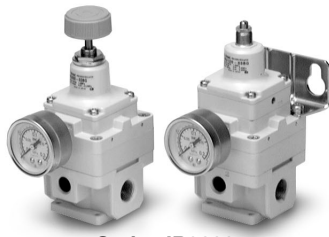

Series IR3000

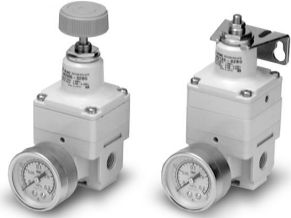

Series IR2000



Series IR1000

## Specification Combinations

●: Standard specifications ○: Combination possible Blank: Combination not possible

Specifications		Symbol	Applicable model				
			IR1000 IR1010 IR1020	IR2000 IR2010 IR2020	IR2120	IR3000 IR3010 IR3020	IR3120
Standard specifications	Set pressure max. 0.2MPa	0	●	●		●	
	Set pressure max. 0.4MPa	1	●	●		●	
	Set pressure max. 0.8MPa	2	●	●	●	●	●
	Connection Rc(PT) 1/8	01	●				
	Connection Rc(PT) 1/4	02		●	●	●	●
	Connection Rc(PT) 3/8	03				●	●
Connection Rc(PT) 1/2	04				●	●	
Accessories	Bracket	B	○	○	○	○	○
	Pressure gauge	G	○	○	○	○	○
Optional specifications	Pressure gauge reverse mounted	R	○	○	○	○	○
	Connection NPT1/8	N01	○				
	Connection NPT1/4	N02		○	○	○	○
	Connection NPT3/8	N03				○	○
	Connection NPT1/2	N04				○	○
	Connection G(PF) 1/8	F01	○				
	Connection G(PF) 1/4	F02		○	○	○	○
	Connection G(PF) 3/8	F03				○	○
	Connection G(PF) 1/2	F04				○	○

## Modular Products and Accessory Combinations

Description	Applicable model		
	IR10□0-□□-X120	IR20□0-□□-X120	IR30□0-□□-X120
1. Air filter	AF20	AF30	AF40
2. Mist separator	AFM20	AFM30	AFM40
3. Interface	Y200	Y300	Y400
4. Interface with bracket	Y200T	Y300T	Y400T

Note 1) Use the made-to-order product (IR□□-X120) for modular connections.

The interface and interface with bracket listed above cannot be connected to the standard type.

Use a conventional connection interface when connecting the standard type with modular connections.

Note 2) The made-to-order product number (IR□□-X120) is for the precision regulator only. For modular connections, please order the applicable products and accessories separately.

### <Combination example>

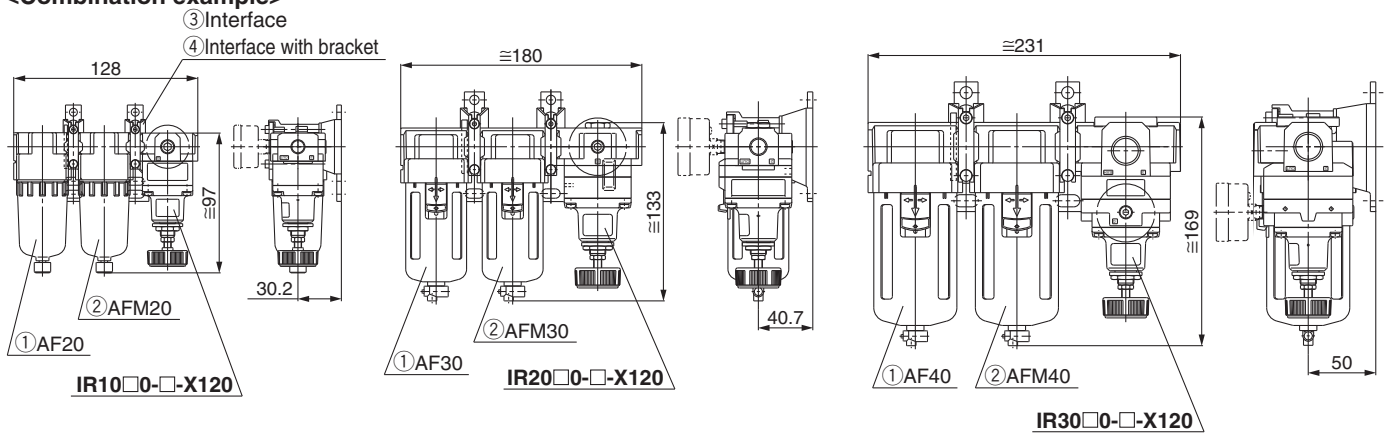

## Accessory (Option)/Part No.

Description	Part no.								
	IR1000	IR1010	IR1020	IR2000	IR2010	IR2020/2120	IR3000	IR3010	IR3020/3120
Bracket	P36201023			P36202028			P362030-20*1		
Pressure gauge*2	G33-2-01	G33-4-01	G33-10-01	G43-2-01	G43-4-01	G43-10-01	G43-2-01	G43-4-01	G43-10-01

\*1 A bracket and two mounting screws (M5 x 35)

To mount the bracket, remove two body screws (M5 x 30) on the name plate on the opposite side and replace the attached two bracket mounting screws (M5 x 35).

\*2 Accuracy ±3% (Full span)

## Construction

### IR1000

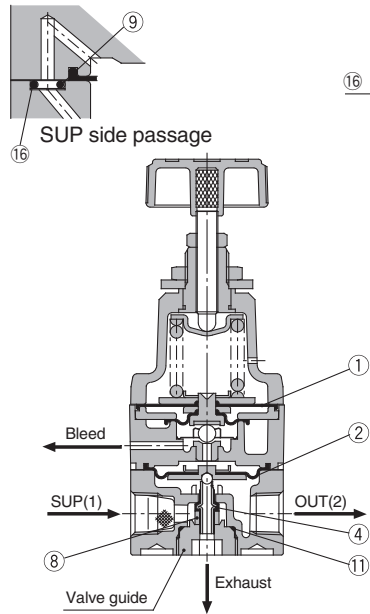

### IR2000

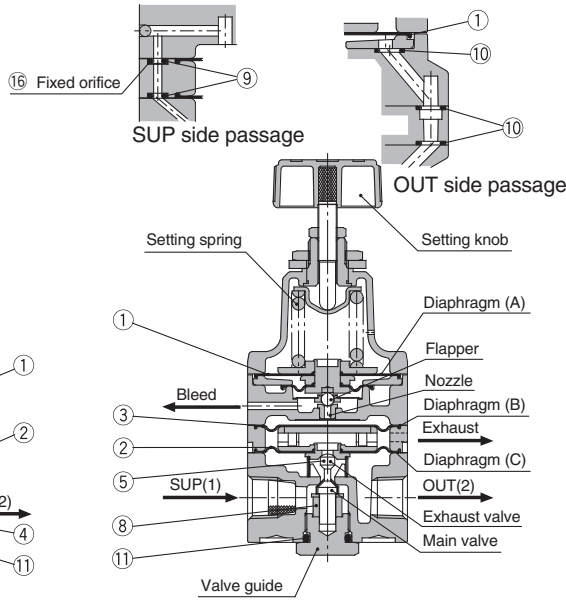

### IR3000

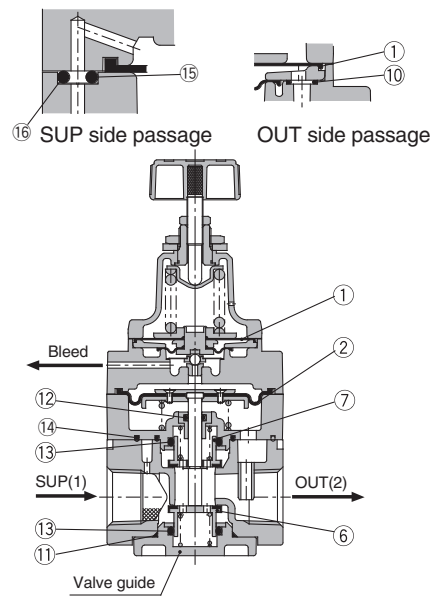

### Operating Principles (for IR2000)

When the setting knob is turned, the nozzle is closed by the flapper allowing the supply air that flows in from the upstream side to pass through the fixed orifice and to act on diaphragm B as nozzle back pressure, the main valve is pushed down by the generated force and the supply pressure flows out to the downstream side. The air pressure that flows in acts on diaphragm C and while opposing the force generated by diaphragm B, it also acts on diaphragm A opposing the compression force of the setting spring and becomes the set pressure. If the set pressure rises too high, diaphragm A is pushed up, the interval between the flapper and the nozzle widens, the nozzle back pressure drops, the balance of diaphragms B and C is broken, the main valve closes, the exhaust valve opens and the excess pressure from the downstream side is discharged to the atmosphere. In this way fine pressure variations are detected by the nozzle/flapper style pilot mechanism, and precise pressure adjustment is performed.

### IR2120

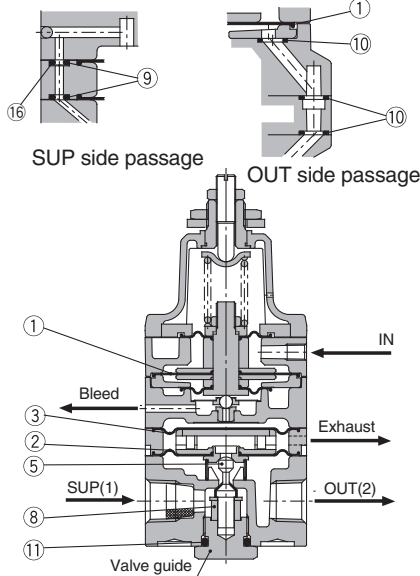

### IR3120

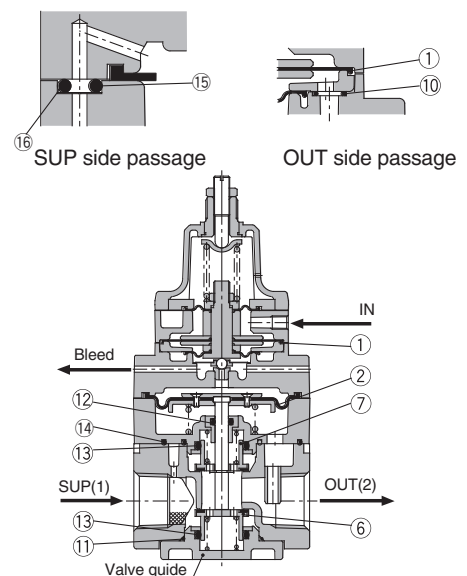

### Replacement Parts

No.	Description	Material	IR10□0		IR20□0		IR30□0		IR2120		IR3120	
			Part no.	Qty.	Part no.	Qty.	Part no.	Qty.	Part no.	Qty.	Part no.	Qty.
1	Diaphragm assembly	NBR, other	P362010-1	1	P362020-2	1	P362020-2	1	P362020-13	1	P362020-13	1
2	Diaphragm assembly	NBR, other	P362010-2	1	P362020-5	1	P362030-1	1	P362020-5	1	P362030-1	1
3	Diaphragm	NBR, other	—	—	P36202019	1	—	—	P36202019	1	—	—
4	Valve	Stainless steel, NBR	P36201058	1	—	—	—	—	—	—	—	—
5	Valve	Stainless steel, NBR	—	—	P36202068#1	—	—	—	P36202068#1	1	—	—
6	Valve	Brass, NBR	—	—	—	—	P36203009#1	1	—	—	P36203009#1	1
7	Valve	Brass, NBR	—	—	—	—	P36203010#1	1	—	—	P36203010#1	1
8	Damper	NBR, other	P36201021	1	P36202026	2	—	—	P36202026	1	—	—
9	O-ring	H-NBR	ø2.5 x 1.05	3	ø1.42 x 1.52	3	—	—	ø1.42 x 1.52	2	—	—
10	O-ring	NBR	—	—	ø4.5 x 1	1	ø4.5 x 1	1	ø4.5 x 1	3	ø4.5 x 1	1
11	O-ring	NBR	ø10 x 1.3	1	JISB2401P11	—	ø27.8 x 1.5	1	JISB2401P11	1	ø27.8 x 1.5	1
12	O-ring	NBR	—	—	—	—	JISB2401P5 Note)	1	—	—	JISB2401P5 Note)	1
13	O-ring	NBR	—	—	—	—	JISB2401P16 Note)	2	—	—	JISB2401P16 Note)	2
14	Seal (A)	NBR	—	—	—	—	P36203015	1	—	—	P36203015	1
15	Seal (B)	NBR	—	—	—	—	P36203016	3	—	—	P36203016	3
16	Fixed throttle	Stainless steel	P36202018	1	P36202018	—	P36203017	1	P36202018	1	P36203017	1
Repair kit no. (A set of above nos. ① to ⑯.)			KT-IR1000		KT-IR2000		KT-IR3000		KT-IR2120		KT-IR3120	

Note) Use mini-flick type.

# Series IR1000/2000/3000

## Dimensions

IR10□0-01□

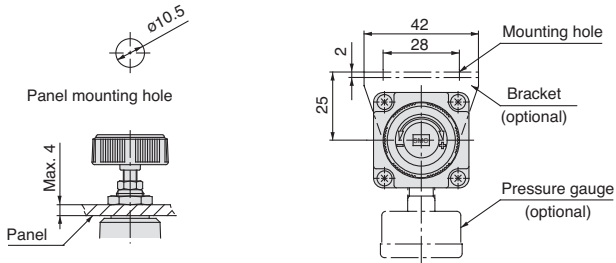
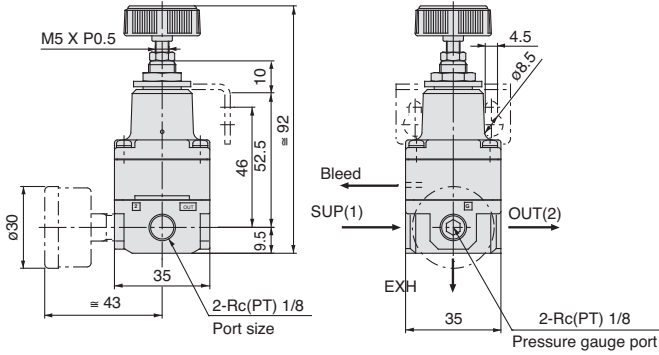

IR20□0-02□

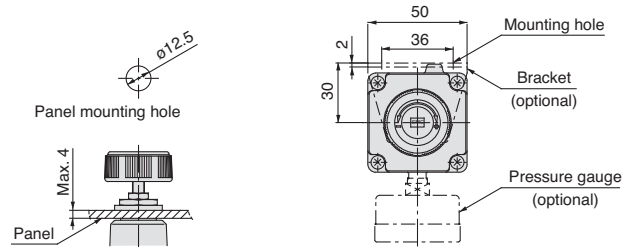
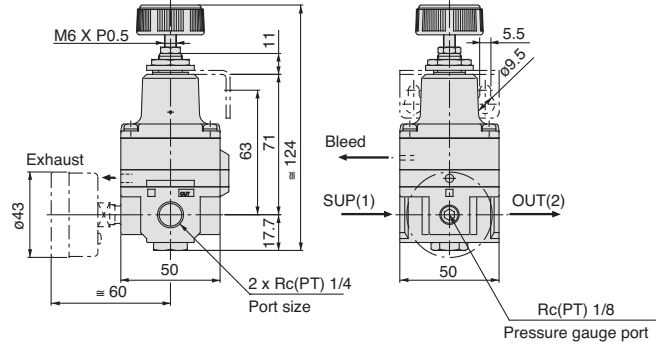

IR30□0-0□□

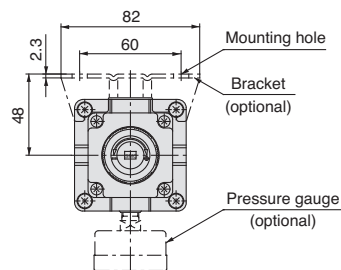
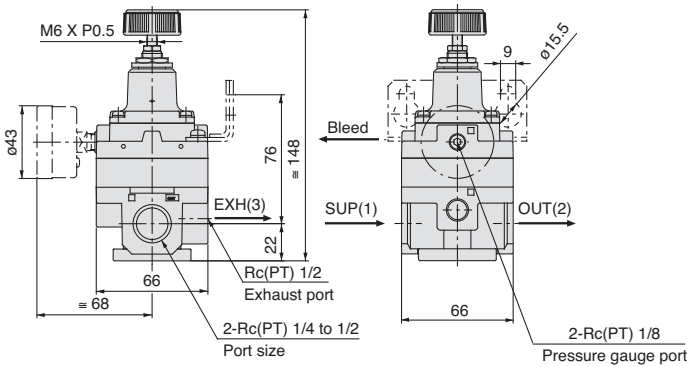

IR2120-02□

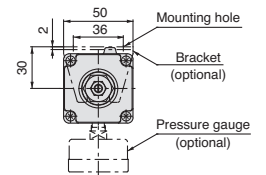
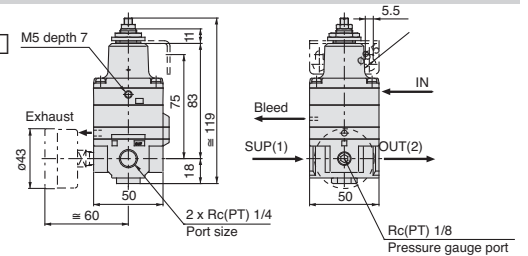

IR3120-0□□

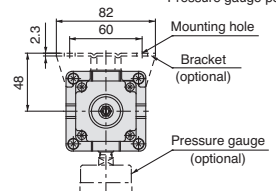
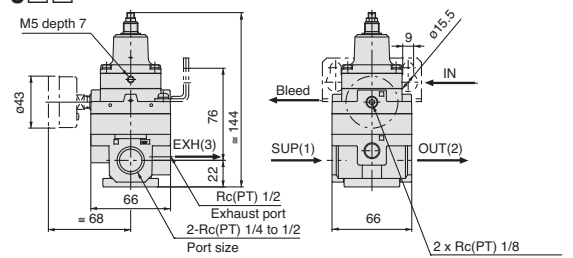



# Series IR1000/2000/3000

## Flow characteristics

\* Testing methods conform to JIS B8372.

**IR1000-01** Conditions: Supply pressure 0.5MPa

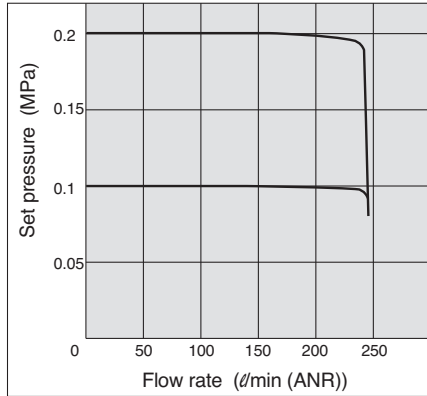

## Relief characteristics

**IR1000-01** Conditions: Back pressure 0.5MPa

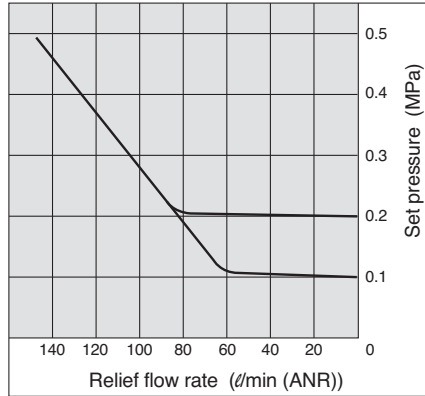

## Pressure characteristics

Conditions: Supply pressure 0.7MPa  
Set pressure 0.2MPa  
Flow rate 0 l/min (ANR)

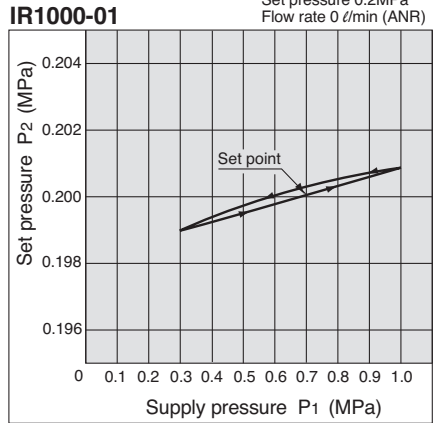

**IR1010-01** Conditions: Supply pressure 0.7MPa

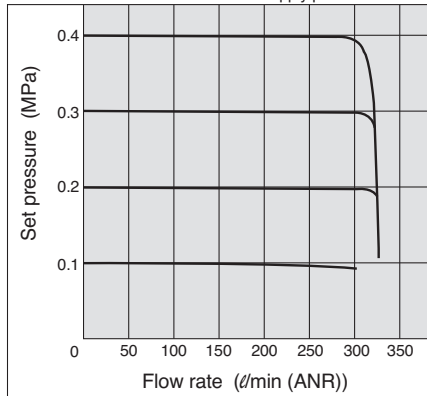

**IR1010-01** Conditions: Back pressure 0.7MPa

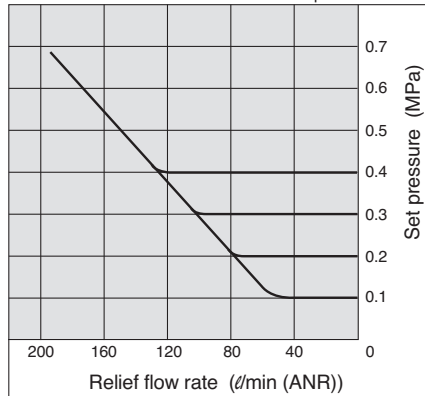

**IR1010-01**

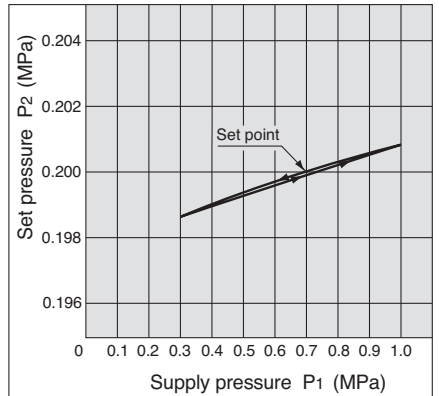

**IR1020-01** Conditions: Supply pressure 1.0MPa

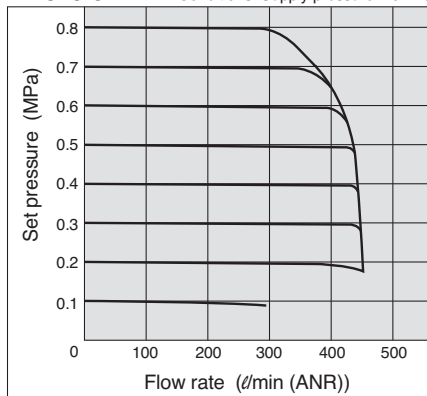

**IR1020-01** Conditions: Back pressure 1.0MPa

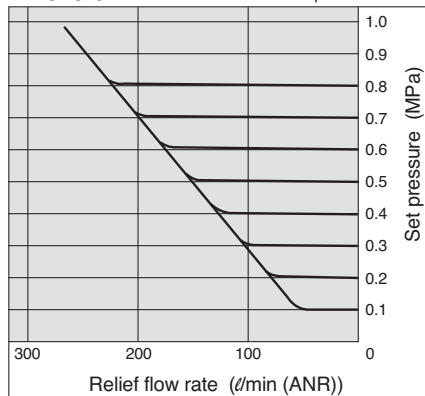

**IR1020-01**

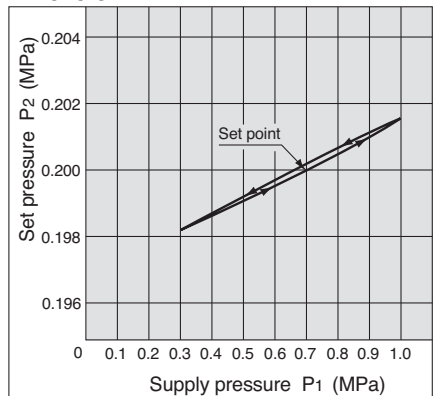

# Series IR1000/2000/3000

## Flow characteristics

\* Testing methods conform to JIS B8372.

**IR2000-02** Conditions: Supply pressure 0.5MPa

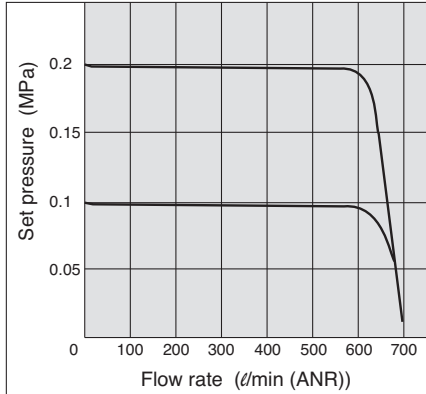

**IR2010-02** Conditions: Supply pressure 0.7MPa

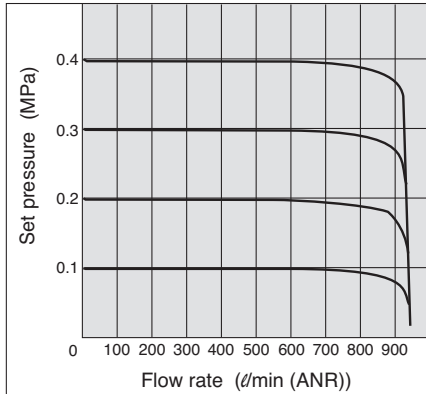

**IR2020-02** Conditions: Supply pressure 1.0MPa

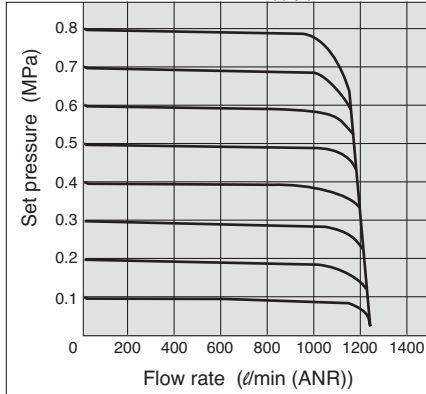

**IR2120-02** Conditions: Supply pressure 1.0MPa

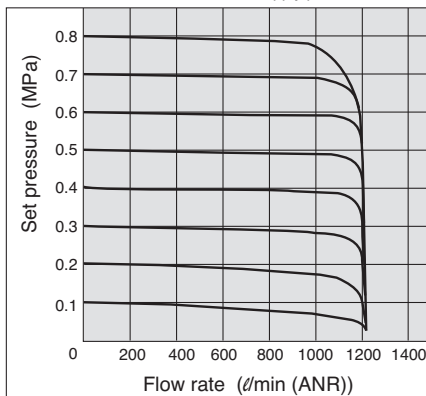

## Relief characteristics

**IR2000-02** Conditions: Back pressure 0.5MPa

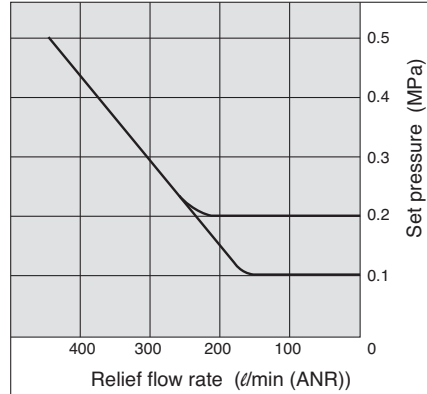

**IR2010-02** Conditions: Back pressure 0.7MPa

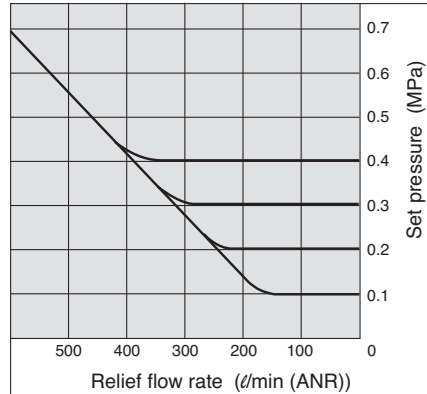

**IR2020-02** Conditions: Back pressure 1.0MPa

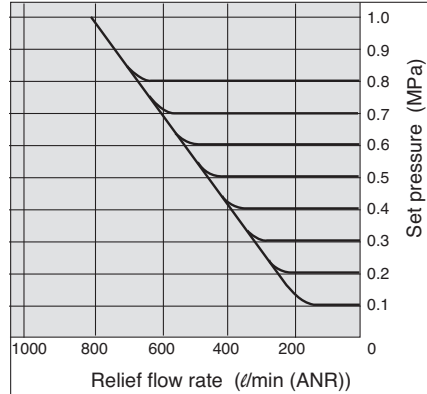

**IR2120-02** Conditions: Back pressure 1.0MPa

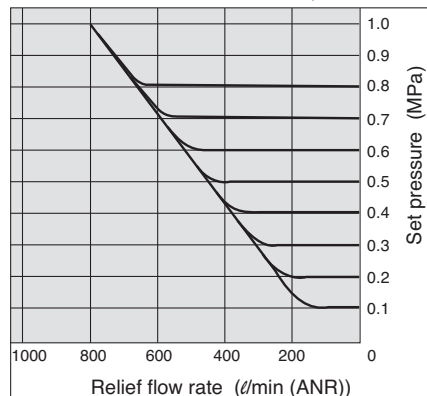

## Pressure characteristics

Conditions: Supply pressure 0.7MPa  
Set pressure 0.2MPa  
Flow rate 0 l/min (ANR)

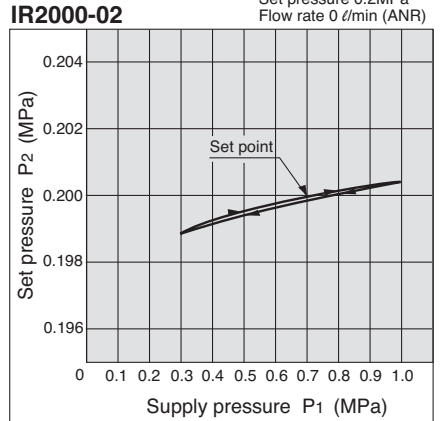

**IR2010-02**

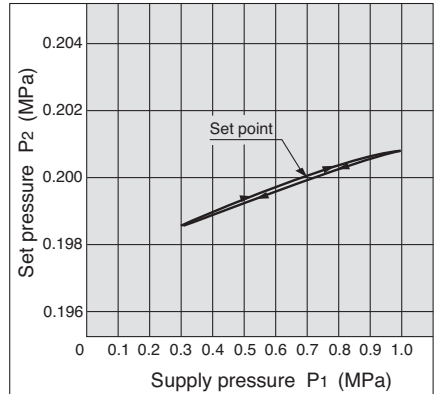

**IR2020-02**

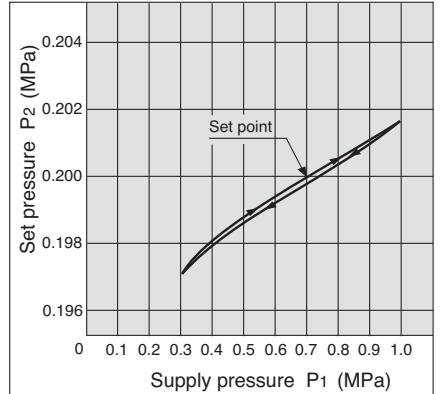

**IR2120-02**

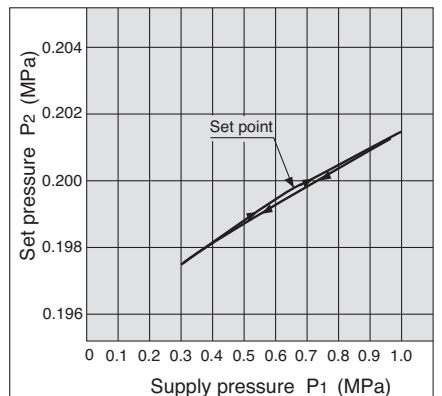

# Series IR1000/2000/3000

## Flow characteristics

\* Testing methods conform to JIS B8372.

**IR3000-03** Conditions: Supply pressure 0.5MPa

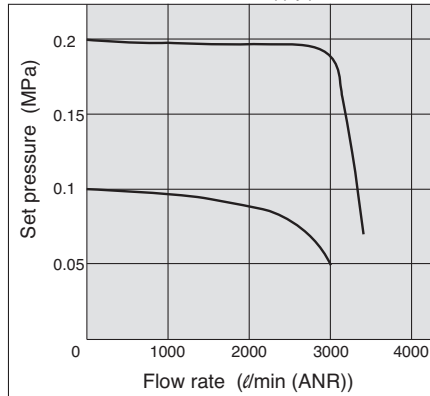

**IR3010-03** Conditions: Supply pressure 0.7MPa

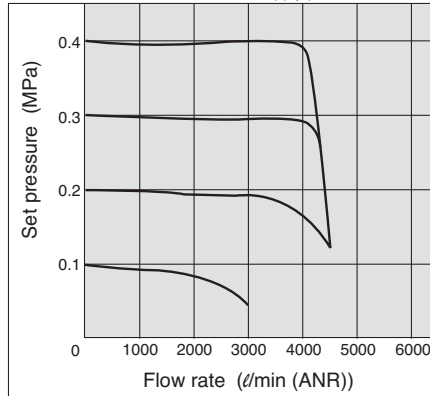

**IR3020-03** Conditions: Supply pressure 1.0MPa

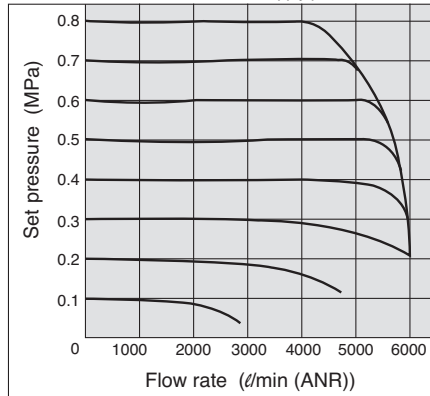

**IR3120-03** Conditions: Supply pressure 1.0MPa

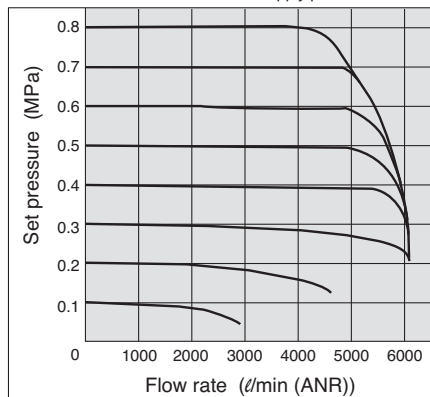

## Relief characteristics

**IR3000-03** Conditions: Back pressure 0.5MPa

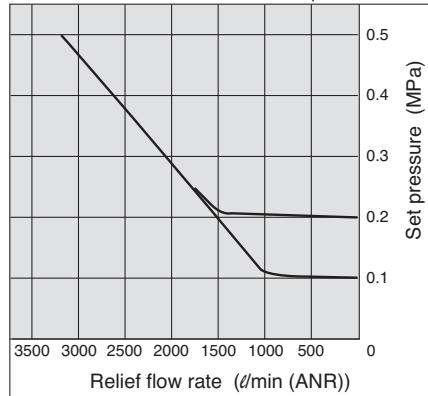

**IR3010-03** Conditions: Back pressure 0.7MPa

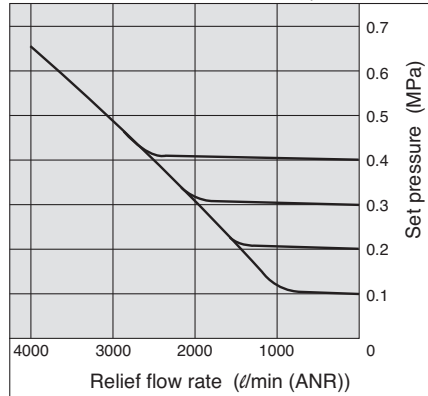

**IR3020-03** Conditions: Back pressure 1.0MPa

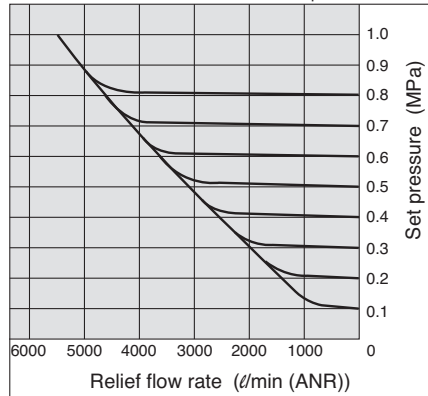

**IR3120-03** Conditions: Back pressure 1.0MPa

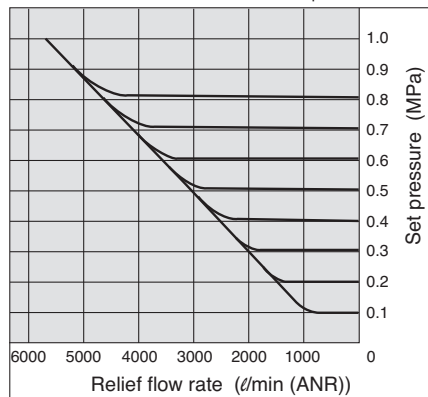

## Pressure characteristics

Conditions: Supply pressure 0.7MPa  
Set pressure 0.2MPa  
Flow rate 0 l/min (ANR)

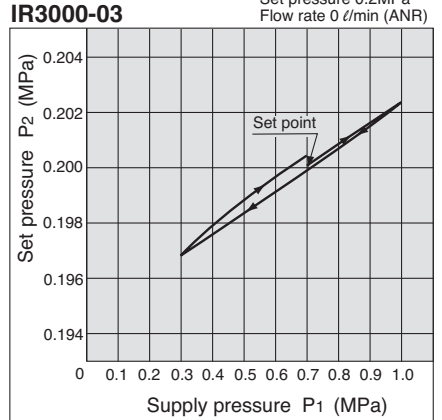

**IR3010-03**

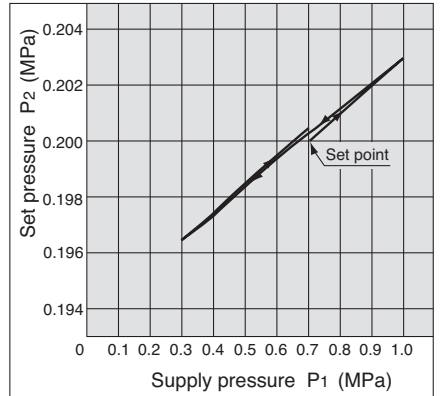

**IR3020-03**

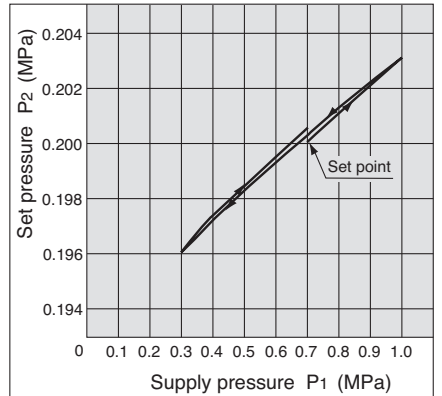

**IR3120-03**

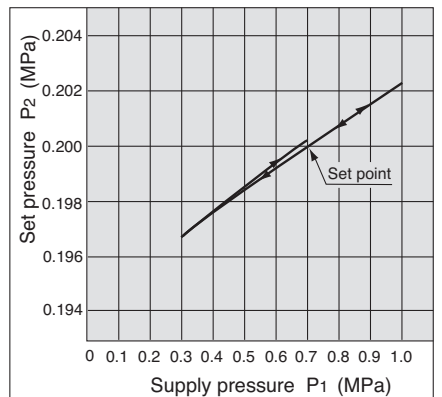

# Series IR1000/2000/3000

## Made to Order Specifications



Contact SMC for detailed dimensions, specifications and delivery times.

### 1 Clean Room

10 — Standard model number

Note) Contact SMC if equipped with pressure gauge.

● Clean room specifications

#### Specifications

Cleanliness	Class 10000
Bleed port	With M5 fitting (applicable tube O.D. ø6)
EXH port	IR1000/2000: M5 fitting (applicable tube O.D. ø6) IR3000: Rc(PT) 1/2 female thread
Grease	Fluoropolymer grease

### 2 Copper-free

External and internal copper parts are changed to stainless steel or aluminum.

20 — Standard model number

Note) Contact SMC if equipped with pressure gauge.

● Copper-free specifications

### 3 Ozone Resistant

Fluoro rubber is used for rubber seal materials.

80 — Standard model number

● Ozone resistant specifications

### 4 For High and Low Temperature Environments

Standard model number — T

● For high/low temperature environments

T	For high temperature
L	For low temperature

#### Specifications

Symbol	T	L
Environment	For high temp. environments	For low temp. environments
Ambient temperature	-5 to 100°C (Max. 80°C with pressure gauge)	-30 to 60°C
Rubber material	FKM	Special NBR or silicon rubber

### 5 Non-Grease

Assembly is performed in an ordinary environment without using grease. However, since parts are not washed, they are not completely oil-free.

Standard model number — X1

● Non-grease specifications

### 6 With Digital Pressure Switch

With digital pressure switch (model no: ISE30A-01-□-ML). Mount a digital pressure switch into the connection port for pressure gauge, as it is not mounted at the time of shipment.



#### Specifications

Made to order part no.	-X465□	
Pressure switch	Set pressure range (MPa)	-0.1 to 1
	Resolution of setting and display (MPa)	0.001
	Power supply voltage	12 to 24 VDC 10%, Ripple (p-p) 10% or less (With reverse connection protection)
	Current consumption	40 mA or less

#### How to Order

Standard model no. (Note) — X465 A

Note) Except for symbol "G"

Note 1) Please contact SMC separately for details about the external dimensions, etc.

Note 2) For details on handling digital pressure switch and specifications, refer to the catalog (CAT.E100-70): Series ISE30A.

Note 3) Digital pressure switch is packed together.

#### Switch specifications

Symbol	Output specifications
A	NPN open collector 1 output
B	PNP open collector 1 output
C	NPN open collector 1 output + Analog voltage output
D	NPN open collector 1 output + Analog current output

### 7 Manifold Specifications (Except type IR2120 and series IR3000)

2 to 8 station manifold type regulators.  
(Please contact SMC regarding 9 or more stations.)

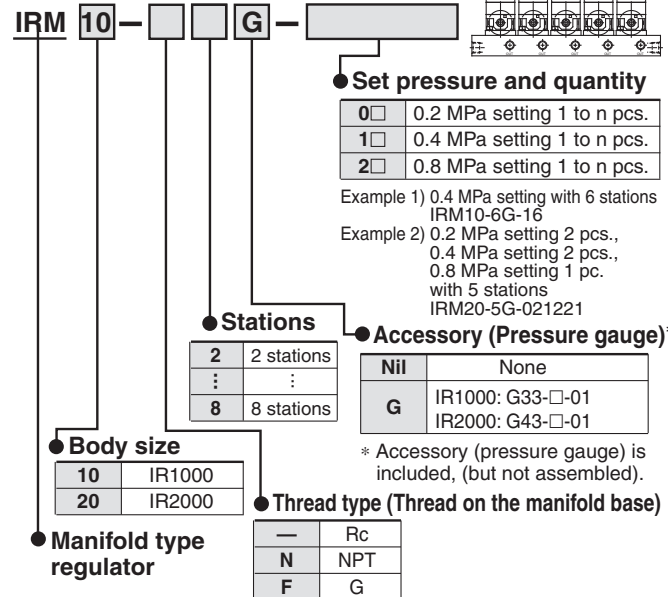
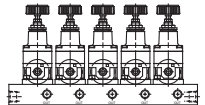

#### Specifications

Stations	2 to 8 stations	
Port	Common SUP	IR1000: 1/4, IR2000: 1/2
	Individual OUT	IR1000: 1/8, IR2000: 1/4
	Individual EXH (From IR body)	
Set pressure	0.2 MPa, 0.4 MPa and 0.8 MPa settings can be combined.	
Accessory (Pressure gauge)	G33-□-01 (IR1000), G43-□-01 (IR2000)	

Note 1) Regulators to be manifolded are counted starting from stations 1 on the left side with the OUT ports in front.

Note 2) When regulators with a different set pressure are manifolded, viewing OUT ports from front, the low pressure range is installed on the left side and high pressure range is on the right side. In case of the "Example 2)" above mentioned, stations 1 and 2 are of 0.2 MPa setting, stations 3 and 4 are of 0.4 MPa setting, and station 5 is of 0.8 MPa setting.

Note 3) Please consult with SMC when a blanking plate is needed.



# Series IR1000/2000/3000 Specific Product Precautions

Be sure to read before handling.

Refer to p.0-26 and 0-27 for Safety Instructions and common precautions on the products mentioned in this catalogue.

## Air Supply

### ⚠ Caution

1. If the supply pressure line contains drainage or dirt, etc., the fixed throttle can become clogged leading to malfunction, and therefore, in addition to an air filter (SMC Series AF) be sure to use a mist separator (SMC Series AM, AFM).

Refer to SMC's "Compressed Air Cleaning Systems" catalogue regarding air quality.

2. Never use a lubricator on the supply side of the regulator, as this will positively cause the fixed throttle to become clogged and lead to malfunction. If lubrication is required for terminal devices, connect a lubricator on the output side of the regulator.

## Maintenance

### ⚠ Warning

1. When the valve guide (refer to construction drawing on p.1.6-6) is to be removed during maintenance, first reduce the set pressure to "0" and completely shut off the supply pressure.
2. When a pressure gauge is to be mounted, remove the plug after reducing the set pressure to "0".

Precautions for IR10□0 only

### ⚠ Warning

1. When remounting the valve guide after removing it for maintenance, use a tightening torque of no more than 0.6Nm. Since the valve guide on this product is made of resin, there is a danger of damage if tightened with a torque exceeding the prescribed value.

## Operation

### ⚠ Caution

1. Do not use a precision regulator outside the range of its specifications as this can cause failure. (Refer to specifications.)
2. When mounting is performed, make connections while confirming port indications.

## Operation

### ⚠ Caution

3. If a directional switching valve (solenoid valve, mechanical valve, etc.) is mounted on the supply side of the regulator and repeatedly switched ON and OFF, wear of the nozzle/flapper section will be accelerated and a discrepancy in the setting value may occur. Therefore, avoid using a directional switching valve on the supply side. In the event a directional switching valve will be used, install it on the output side of the regulator.
4. Air is normally discharged from the bleed port (the hole on the side of the body's mid-section). This is a necessary consumption of air based on the construction of the precision regulator, and is not an abnormality.
5. Be sure to tighten the lock nut after pressure adjustment.

Precautions for IR30□0, IR3120 only

### ⚠ Caution

1. The supply pressure is relatively high (approx. 0.5MPa or more), the set pressure is low (approx. 0.1MPa or less), and when operated with the output side released to the atmosphere, there may be pulsations in the setting side pressure. In this kind of situation, operate with the supply pressure reduced as much as possible, or increase the set pressure somewhat and restrict the output line (add and adjust a stop valve, etc.).
2. The capacity of the output side is large, and when used for the purpose of a relief function, the exhaust sound will be loud when being relieved. Therefore, operate with a silencer (SMC Series AN) mounted on the exhaust port (EXH port). The connection is Rc(PT) 1/2.

Precautions for IR2120, IR3120 (air operated style) only

### ⚠ Caution

1. Since the output of types IR2120 and IR3120 is the same pressure as the input signal pressure, select a type of regulator (general purpose or precision type) for input signal pressure adjustment according to the application.
2. The screw on the topmost section is a zero point adjustment screw which is locked at the factory and requires no adjustment for operation.



# Series IR1000/2000/3000 Precision Regulator Precautions

Be sure to read before handling.  
Refer to p.0-26 and 0-27 for Safety Instructions and common precautions on the products mentioned in this catalogue.

## Piping

### Warning

1. Screw piping together with the recommended proper torque while holding the side with female threads.

Looseness or faulty sealing will occur if tightening torque is insufficient, while thread damage will result if the torque is excessive. Furthermore, if the side with the female threads is not held while tightening, excessive force will be applied directly to piping brackets, etc. causing damage or other problems.

Recommended proper torque Nm

Connection thread	1/8	1/4	3/8	1/2
Torque	7 to 9	12 to 14	22 to 24	28 to 30

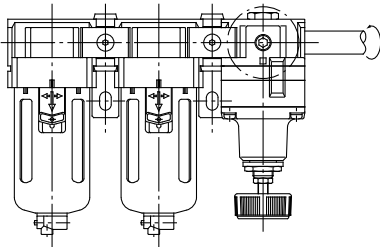

2. Do not allow twisting or bending moment to be applied other than the weight of the equipment itself.

Provide separate support for external piping, as damage may otherwise occur.

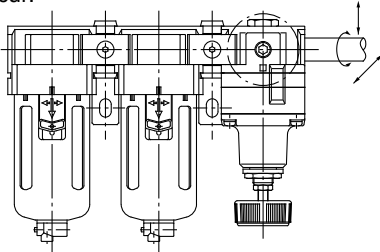

3. Since excessive moment loads and the propagation of vibrations, etc. can easily result from inflexible piping made of steel, etc., avoid these problems by using flexible tubing for intermediate connections.

## Piping

### Caution

1. Preparation before piping

Before piping is connected, it should be thoroughly blown out with air (flushing) or washed to remove cutting chips, cutting oil and other debris from inside the pipe.

2. Wrapping of pipe tape

When connecting pipes and fittings, etc., be sure that cutting chips from the pipe threads and sealing material do not get inside.

Further, when pipe tape is used, leave 1.5 to 2 thread ridges exposed at the end of the pipe/fitting.

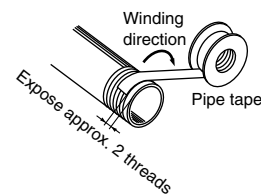

## Operating Environment

### Warning

1. Do not operate in locations having an atmosphere of corrosive gases, chemicals, sea water, water or steam, or where there will be contact with the same.
2. Do not operate in locations where vibration or impact occurs.
3. In locations which receive direct sunlight, provide a protective cover, etc.
4. In locations near heat sources, block off any radiated heat.
5. In locations where there is contact with spatter from water, oil or solder, etc., implement suitable protective measures.

## Air Supply

### Warning

1. These products are designed for use with compressed air. Contact SMC if any other fluid will be used.
2. Do not use compressed air which includes chemicals, synthetic oils containing organic solvents, salt, or corrosive gases, etc., as this can cause damage or malfunction.
3. If drainage is not removed from air filters and mist separators, it can flow out to the downstream side and lead to the malfunction of pneumatic equipment.  
In cases where the management of drainage removal will be difficult, the use of filters with auto drains is recommended.

## Safety Instructions

These safety instructions are intended to prevent hazardous situations and/or equipment damage. These instructions indicate the level of potential hazard with the labels of “**Caution**,” “**Warning**” or “**Danger**.” They are all important notes for safety and must be followed in addition to International Standards (ISO/IEC)\*1), and other safety regulations.

 **Caution:** **Caution** indicates a hazard with a low level of risk which, if not avoided, could result in minor or moderate injury.

 **Warning:** **Warning** indicates a hazard with a medium level of risk which, if not avoided, could result in death or serious injury.

 **Danger:** **Danger** indicates a hazard with a high level of risk which, if not avoided, will result in death or serious injury.

- \*1) ISO 4414: Pneumatic fluid power – General rules relating to systems.  
 ISO 4413: Hydraulic fluid power – General rules relating to systems.  
 IEC 60204-1: Safety of machinery – Electrical equipment of machines.  
 (Part 1: General requirements)  
 ISO 10218-1: Manipulating industrial robots - Safety.  
 etc.

### Warning

#### 1. The compatibility of the product is the responsibility of the person who designs the equipment or decides its specifications.

Since the product specified here is used under various operating conditions, its compatibility with specific equipment must be decided by the person who designs the equipment or decides its specifications based on necessary analysis and test results. The expected performance and safety assurance of the equipment will be the responsibility of the person who has determined its compatibility with the product. This person should also continuously review all specifications of the product referring to its latest catalogue information, with a view to giving due consideration to any possibility of equipment failure when configuring the equipment.

#### 2. Only personnel with appropriate training should operate machinery and equipment.

The product specified here may become unsafe if handled incorrectly. The assembly, operation and maintenance of machines or equipment including our products must be performed by an operator who is appropriately trained and experienced.

#### 3. Do not service or attempt to remove product and machinery/equipment until safety is confirmed.

- The inspection and maintenance of machinery/equipment should only be performed after measures to prevent falling or runaway of the driven objects have been confirmed.
- When the product is to be removed, confirm that the safety measures as mentioned above are implemented and the power from any appropriate source is cut, and read and understand the specific product precautions of all relevant products carefully.
- Before machinery/equipment is restarted, take measures to prevent unexpected operation and malfunction.

#### 4. Contact SMC beforehand and take special consideration of safety measures if the product is to be used in any of the following conditions.

- Conditions and environments outside of the given specifications, or use outdoors or in a place exposed to direct sunlight.
- Installation on equipment in conjunction with atomic energy, railways, air navigation, space, shipping, vehicles, military, medical treatment, combustion and recreation, or equipment in contact with food and beverages, emergency stop circuits, clutch and brake circuits in press applications, safety equipment or other applications unsuitable for the standard specifications described in the product catalogue.
- An application which could have negative effects on people, property, or animals requiring special safety analysis.
- Use in an interlock circuit, which requires the provision of double interlock for possible failure by using a mechanical protective function, and periodical checks to confirm proper operation.

### Caution

#### 1. The product is provided for use in manufacturing industries.

The product herein described is basically provided for peaceful use in manufacturing industries.

If considering using the product in other industries, consult SMC beforehand and exchange specifications or a contract if necessary.

If anything is unclear, contact your nearest sales branch.

## Limited warranty and Disclaimer/ Compliance Requirements

The product used is subject to the following “Limited warranty and Disclaimer” and “Compliance Requirements”.

Read and accept them before using the product.

### Limited warranty and Disclaimer

- The warranty period of the product is 1 year in service or 1.5 years after the product is delivered, whichever is first.\*2)  
 Also, the product may have specified durability, running distance or replacement parts. Please consult your nearest sales branch.
- For any failure or damage reported within the warranty period which is clearly our responsibility, a replacement product or necessary parts will be provided.  
 This limited warranty applies only to our product independently, and not to any other damage incurred due to the failure of the product.
- Prior to using SMC products, please read and understand the warranty terms and disclaimers noted in the specified catalogue for the particular products.

\*2) Vacuum pads are excluded from this 1 year warranty.

A vacuum pad is a consumable part, so it is warranted for a year after it is delivered. Also, even within the warranty period, the wear of a product due to the use of the vacuum pad or failure due to the deterioration of rubber material are not covered by the limited warranty.

### Compliance Requirements

- The use of SMC products with production equipment for the manufacture of weapons of mass destruction (WMD) or any other weapon is strictly prohibited.
- The exports of SMC products or technology from one country to another are governed by the relevant security laws and regulations of the countries involved in the transaction. Prior to the shipment of a SMC product to another country, assure that all local rules governing that export are known and followed.

## Safety Instructions

Be sure to read “Handling Precautions for SMC Products” (M-E03-3) before using.

### SMC Corporation (Europe)

Austria	☎+43 (0)22622800	www.smc.at	office@smc.at
Belgium	☎+32 (0)33551464	www.smc-pneumatics.be	info@smc-pneumatics.be
Bulgaria	☎+359 (0)2807670	www.smc.bg	office@smc.bg
Croatia	☎+385 (0)13707288	www.smc.hr	office@smc.hr
Czech Republic	☎+420 541424611	www.smc.cz	office@smc.cz
Denmark	☎+45 70252900	www.smc.dk.com	smc@smcdk.com
Estonia	☎+372 6510370	www.smc-pneumatics.ee	smc@smc-pneumatics.ee
Finland	☎+358 207513513	www.smc.fi	smcffi@smc.fi
France	☎+33 (0)164761000	www.smc-france.fr	promotion@smc-france.fr
Germany	☎+49 (0)61034020	www.smc.de	info@smc.de
Greece	☎+30 210 2717265	www.smchellas.gr	sales@smchellas.gr
Hungary	☎+36 23511390	www.smc.hu	office@smc.hu
Ireland	☎+353 (0)14039000	www.smc-pneumatics.ie	sales@smc-pneumatics.ie
Italy	☎+39 0292711	www.smcitalia.it	mailbox@smcitalia.it
Latvia	☎+371 67817700	www.smc.lv	info@smclv.lv

Lithuania	☎+370 5 2308118	www.smclt.lt	info@smclt.lt
Netherlands	☎+31 (0)205318888	www.smc-pneumatics.nl	info@smc-pneumatics.nl
Norway	☎+47 67129020	www.smc-norge.no	post@smc-norge.no
Poland	☎+48 (0)222119616	www.smc.pl	office@smc.pl
Portugal	☎+351 226166570	www.smc.eu	postpt@smc.smces.es
Romania	☎+40 213205111	www.smcromania.ro	smcromania@smcromania.ro
Russia	☎+7 8127185445	www.smc-pneumatik.ru	info@smc-pneumatik.ru
Slovakia	☎+421 (0)413213212	www.smc.sk	office@smc.sk
Slovenia	☎+386 (0)73885412	www.smc.si	office@smc.si
Spain	☎+34 902184100	www.smc.eu	post@smc.smces.es
Sweden	☎+46 (0)86031200	www.smc.nu	post@smc.nu
Switzerland	☎+41 (0)523963131	www.smc.ch	info@smc.ch
Turkey	☎+90 212 489 0 440	www.smc-pneumatik.com.tr	info@smc-pneumatik.com.tr
UK	☎+44 (0)845 121 5122	www.smc-pneumatics.co.uk	sales@smc-pneumatics.co.uk