





Best Pneumatics 4

Pressure Gauge Guide

General Purpose Pressure Gauge: G□	P.1.15-2
Oil Free/External Parts Copper Free Pressure Gauge: G46E	P.1.15-8
Pressure Gauge for Clean Regulator: G46-□-□-SR	P.1.15-9

Pressure Gauge Guide

General Purpose Pressure Gauge

	Size (O.D.)	Model (Type)	Indication precision %FS	Gauge range		Connecting thread	Material			Indication units ⁽¹⁾		Attachment ⁽²⁾	
				MPa	kgf/cm ²		Case	Clear cover	Stud	MPa	MPa & kgf/cm ²		
General purpose 	ø15	G15 (DTtype)	5	0 to 1.0	—	R(PT) 1/8 Male thread, M5 Female	Zinc die cast (Sun-coat treated)	Poly-carbonate	Zinc die cast (Sun-coat treated)	●	—	P.1.15-2	
	ø26	G27 (DTtype)		0 to 1.0	—	R(PT) 1/16 Male thread	—	—	—	●	—		
With limit indicator 	ø37	G36 (DTtype) GA36 (ATtype)	3	0 to 0.2 0 to 0.4 0 to 0.7 0 to 1.0 0 to 1.5	—	R(PT) 1/8	Rolled steel (Black melamine painted)	Poly-carbonate	Brass	—	●	—	P.1.15-4
With limit indicator 	ø42	G46 (DTtype)	3	0 to 0.2 0 to 0.4 0 to 0.7 0 to 1.0 0 to 1.5	0 to 1 0 to 4 0 to 7 0 to 10 0 to 15	R(PT) 1/8 R(PT) 1/4	Rolled steel (Black melamine painted)	Poly-carbonate	Brass	—	●	Cover ring ass'y	P.1.15-5
		GA46 (ATtype)		R(PT) 1/8	—								
	ø43	G43 (DTtype)	3	0 to 0.2 0 to 0.3 0 to 0.4 0 to 0.6 0 to 0.7 0 to 1.0	0 to 2 0 to 3 0 to 4 0 to 6 0 to 7 0 to 10	R(PT) 1/8 R(PT) 1/4	Stainless steel	Glass	Brass	—	●	—	P.1.15-6



Note 1) Consult SMC for psi and bar scale indication and connecting thread "NPT".
Note 2) Possible for use in a panel mounting.

Oil Free/External Parts Copper Free Pressure Gauge

	Size (O.D.)	Model (Type)	Indication precision %FS	Gauge range		Connecting thread	Material			Indication units ⁽¹⁾		Attachment ⁽²⁾	
				MPa	kgf/cm ²		Case	Clear cover	Stud	MPa	MPa & kgf/cm ²		
With limit indicator 	ø42	G46E (DT type)	3	0 to 0.2 0 to 0.4 0 to 0.7 0 to 1.0	—	R(PT) 1/8 R(PT) 1/4	Rolled steel (Black melamine painted)	Poly-carbonate (Hard coated)	Brass Electroless nickel plated	—	●	Cover ring ass'y	P.1.15-8
							Oil free (Degreased)						



Note 1) Consult SMC for psi and bar scale indication and connecting thread "NPT".
Note 2) Possible for use in a panel mounting.

Pressure Gauge for Clean Regulator

	Size (O.D.)	Model (Type)	Indication precision %FS	Gauge range		Connecting thread	Material			Indication units ⁽¹⁾		Attachment ⁽²⁾	
				MPa	kgf/cm ²		Case	Clear cover	Stud	MPa	MPa & kgf/cm ²		
With limit indicator 	ø42	G46-□-SR (DT type)	3	0 to 0.2 0 to 0.4 0 to 0.7 0 to 1.0	—	R(PT) 1/4	SUS 304 (Black melamine painted)	Poly-carbonate (Hard coated)	SUS 316	—	●	—	P.1.15-9
							Oil free/Water free ⁽²⁾						



Note 1) Consult SMC for psi and bar scale indication and connecting thread "NPT".
Note 2) Refer to the p.1.15-8 for further information.

General Purpose Pressure Gauge

G15 (DT type)/G27 (DT type)

O.D.: $\varnothing 15$
 $\varnothing 26$

RoHS



G15-10-01



G27-10-R1

Standard Specifications

Model		G15	G27
Type		Back side thread	
Port size ⁽¹⁾		R 1/8: M5 (Female thread)	R 1/8
Fluid ^{(2) (3)}		Air	
Indication precision ⁽⁴⁾		±5% F.S. (Full span)	
Material	Case (Surface treatment)	Zinc die-casted (Black graphite coated)	
	Clear cover	Polycarbonate	
	Stud (Surface treatment)	Zinc die-casted (Black graphite coated)	
	Bourdon tube	Brass	
Weight (kg)		0.01	0.015

• Caution on handling: When drain or oil, etc. gets into the gauge, it may result in a malfunction.

Note 1) When mounting a pressure gauge, use caution not to tighten excessively. Excessive tightening will cause product to be damaged. Use a pipe tape for sealing.

Note 2) Water cannot be used as an operating fluid. Because the clearance gap of the air passage of the Bourdon tube is very small. Water will block the gap and cause a malfunction.

Similarly, when using other fluids, please consult with SMC for fluid compatibility information concerning possible corrosion and response delay, etc.

Note 3) Avoid freezing as this may cause a malfunction.

Note 4) The guaranteed temperature range is 23°C ±5°C.

Model (Standard)

Model	Pressure range ⁽¹⁾		Indication unit	Connection thread
	MPa			
G15-10-01	0 to 1.0		MPa	R 1/8, M5 (Female thread)
G27-10-R1	0 to 1.0		MPa	R 1/8

Note 1) Do not apply more excessive pressure than max. pressure display. It will be a cause of malfunction.

Model (Made to Order)

Other versions of this unit can be made on a Made-to-Order basis.

Please consult with SMC for details, as delivery times may be extended.

Model	Pressure range ⁽¹⁾		Indication unit	Connection thread
	MPa	psi		
G27-10-M5	0 to 1.0	—	MPa	M5 (Female thread)
G27-P10-R1-X30 ⁽²⁾	0 to 1.0	0 to 150	MPa, psi	R 1/8

Note 1) Do not apply more excessive pressure than max. pressure display. It will be a cause of malfunction.

Note 2) Under the New Measurement Law, products for overseas use only (SI unit type for use in Japan)

Pressure Gauge Guide

General Purpose Pressure Gauge

G15 (DT type)/G27 (DT type)

O.D.: $\phi 15$
 $\phi 26$

RoHS

How to Order

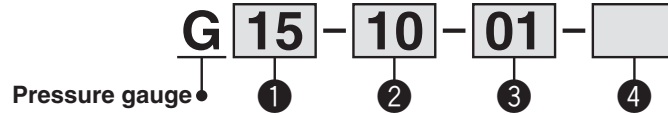

	Symbol	Description	①	
			Size	
			G15	G27
	+			
② Max. display pressure	10 ⁽¹⁾	1.0 MPa	●	●
	P10 ^{(1), (2)}	1.0 MPa, 150 psi	—	○ ⁽³⁾
	+			
③ Connection thread	01	R 1/8: M5 (Female thread)	●	—
	R1	R 1/8	—	●
		R 1/16	—	●
	+			
④ Special specification <small>Note 4)</small>	—	—	●	●
	X30	Both MPa and psi	—	○ ⁽³⁾

Note 1) Pressure other than 1.0 MPa is not available.

Note 2) This symbol must be used with Special specification "X30."

Note 3) Under the New Measurement Law, products for overseas use only (SI unit type for use in Japan)

Note 4) Wetted parts stainless steel specifications are not available.

Note 5) Cover ring assembly is not available.

Dimensions (Except Made-to-Order products)

G15-10-01

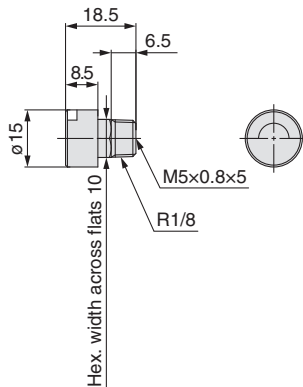

G27-10-^{R1}₀₁

21 (Width across flats)

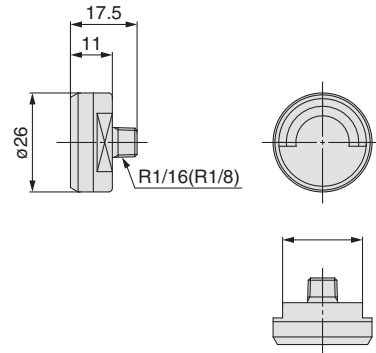

* The dimensions in () : Connection thread R 1/8

Pressure Gauge Guide

General Purpose Pressure Gauge/With Limit Indicator

G46(DT type)/GA46(AT type)

O.D.: $\phi 42$

RoHS



G46-10-02M-C

Dimensions

* The dimensions in ():
Connecting thread R 1/4

G46-□□-01 to 02 (M)

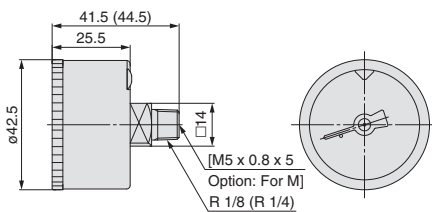

G46-□□-01 to 02 (M)-C

G46-□□-01 to 02 (M)-C2

With cover ring assembly
(For panel mount)

Type C
(Clear cover is not removable.)

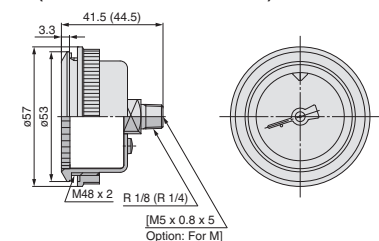

Type C2

(Clear cover is removable. The wrench flats protrude.)

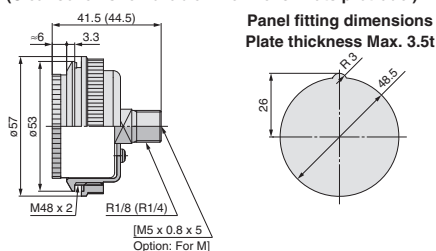

GA46-□□-01 to 02

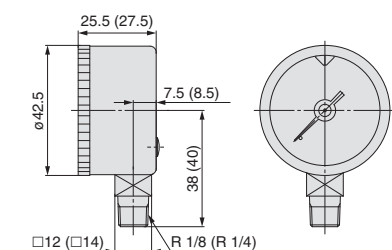

Standard Specifications

Model		G46	GA46
Type		Back side thread	Vertical side thread
Port size ⁽¹⁾		R 1/8, R 1/4 (Option M: with M5 female thread)	
Fluid ^{(2) (4)}		Air	
Indication precision ⁽⁵⁾		±3% F.S. (Full span)	
Material	Case (Surface treatment)	Rolled steel (Electrodeposition coating black)	Stainless steel (Black melamine painted)
	Clear cover ⁽³⁾	Polycarbonate Part no.: G46-00-00-4	Polycarbonate Part no.: G46-00-00-3
	Stud (Surface treatment)	Aluminum die-casted (Black disulfide molybdenum coated)	Brass
	Bourdon tube	Brass	
Weight (kg)		0.05	0.075
Attachment: With cover ring assembly	C	Part no.: 1305104-1A	—
	C2	Part no.: 1305104-9A	—

Note 1) When mounting a pressure gauge, use caution not to tighten excessively. Excessive tightening will cause product to be damaged. Use a pipe tape for sealing.

Note 2) Not applicable to water as fluid because its stud is made from aluminum die-casting. Water may cause corrosion and block the air passage.

Note 3) Clear cover: G46-00-00-4 is not compatible with G46-00-00-3.

Note 4) Avoid freezing as this may cause a malfunction.

Note 5) The guaranteed temperature range is 23°C ±5°C.

Model (Standard)

Model	Pressure range ⁽¹⁾		Indication unit	Connection thread	Note
	MPa	psi			
G46-2-01/02	0 to 0.2		MPa	R 1/8, 1/4	—
G46-4-01/02	0 to 0.4				
G46-7-01/02	0 to 0.7				
G46-10-01/02	0 to 1.0				
G46-2-01 to 02M	0 to 0.2				
G46-4-01 to 02M	0 to 0.4			R 1/8, 1/4 M5 (Female thread)	
G46-7-01 to 02M	0 to 0.7				
G46-10-01 to 02M	0 to 1.0				
GA46-10-01 to 02	0 to 1.0				

Note 1) Do not apply pressure more than the maximum display pressure. This will cause a malfunction.

Model (Made to Order)

Other versions of this unit can be made on a Made-to-Order basis. Please consult with SMC for details, as delivery times may be extended.

Model	Pressure range ⁽¹⁾		Indication unit	Connection thread	Note
	MPa	psi			
G46-2-01 to 02-C/C2	0 to 0.2	—	MPa	R 1/8, 1/4	With cover ring assembly
G46-4-01 to 02-C/C2	0 to 0.4	—			
G46-7-01 to 02-C/C2	0 to 0.7	—			
G46-10-01 to 02-C/C2	0 to 1.0	—			
G46-2-01 to 02M-C/C2	0 to 0.2	—			
G46-4-01 to 02M-C/C2	0 to 0.4	—			
G46-7-01 to 02M-C/C2	0 to 0.7	—			
G46-10-01 to 02M-C/C2	0 to 1.0	—			
G46-P2-01 to 02-X30 ⁽²⁾	0 to 0.2	0 to 30			
G46-P10-01 to 02-X30 ⁽²⁾	0 to 1.0	0 to 150	MPa, psi	R 1/8, 1/4	—
G46-P2-01 to 02-C/C2-X30 ⁽²⁾	0 to 0.2	0 to 30			
G46-P10-01 to 02-C/C2-X30 ⁽²⁾	0 to 1.0	0 to 150			
G46-15-02	0 to 1.5	—	MPa	R 1/4	—

Note 1) Do not apply pressure more than the maximum display pressure. This will cause a malfunction.

Note 2) Under the New Measurement Law, products for overseas use only (SI unit type for use in Japan).

General Purpose Pressure Gauge

G43 (DT type)

O.D.: $\phi 43$

RoHS



G43-10-01

Standard Specifications

Model		G43
Type		Back side thread
Port size ⁽¹⁾		R 1/8, R 1/4
Fluid ⁽²⁾		Air
Indication precision ⁽³⁾		±3% F.S. (Full span)
Material	Case	Stainless steel
	Clear cover	Glass
	Stud	Brass
	Bourdon tube	Brass
Weight [kg]		0.07
Applicable model		IP200, IP8000, IR2000, IR3000, IT2000, IT4000

Note 1) When mounting a pressure gauge, use caution not to tighten excessively. Excessive tightening will cause product to be damaged. Use a pipe tape for sealing.

Note 2) Avoid freezing as this may cause a malfunction.

Note 3) The guaranteed temperature range is 23°C ±5°C.

Model (Standard)

Model	Pressure range ⁽¹⁾	Indication unit	Connection thread	Note
	MPa			
G43-2-01 to 02	0 to 0.2	MPa	R 1/8, R 1/4	—
G43-4-01 to 02	0 to 0.4			
G43-6-01	0 to 0.6		R 1/8	
G43-7-01 to 02	0 to 0.7		R 1/8, R 1/4	
G43-10-01 to 02	0 to 1.0			

Note 1) Do not apply pressure more than the maximum display pressure. This will cause a malfunction.

Model (Made to Order)

Model	Pressure range ⁽¹⁾	Indication unit	Connection thread	Note
	MPa			
G43-2-01 to 02-X2	0 to 0.2	MPa	R 1/8, R 1/4	X2: Stud parts nickle plated
G43-4-01 to 02-X2	0 to 0.4			
G43-6-01-X2	0 to 0.6		R 1/8	
G43-7-01 to 02-X2	0 to 0.7		R 1/8, R 1/4	
G43-10-01 to 02-X2	0 to 1.0			
G43-2-01 to 02-X3	0 to 0.2		R 1/8, R 1/4	X3: Wetted parts stainless steel
G43-4-01 to 02-X3	0 to 0.4			
G43-6-01-X3	0 to 0.6		R 1/8	
G43-7-01 to 02-X3	0 to 0.7		R 1/8, R 1/4	X4: Oil-free (Wetted parts degreasing)
G43-10-01 to 02-X3	0 to 1.0			
G43-2-01-X4	0 to 0.2	R 1/8, R 1/4		
G43-4-01 to 02-X4	0 to 0.4			
G43-7-01 to 02-X4	0 to 0.7			
G43-10-01 to 02-X4	0 to 1.0			

Note 1) Do not apply pressure more than the maximum display pressure. This will cause a malfunction.

Dimensions (Except Made-to-Order products)

G43-□-01 to 02

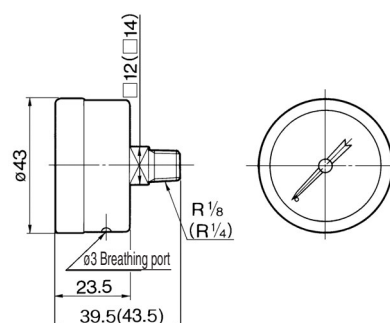

* The dimensions in (): Connection thread R 1/4

Pressure Gauge Guide

General Purpose Pressure Gauge

G43 (DT type)

O.D.: $\phi 43$

RoHS

How to Order

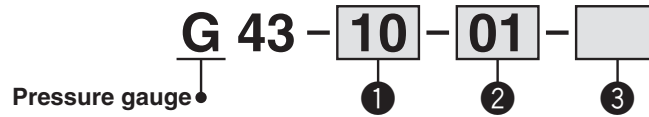

	Symbol	Description	G43
	+		
① Max. display pressure	2	0.2 MPa	●
	3	0.3 MPa	●
	4	0.4 MPa	●
	6	0.6 MPa	●
	7	0.7 MPa	●
	10	1.0 MPa	●
	P2 ⁽¹⁾	0.2 MPa, 30 psi	○ ⁽²⁾
	P4 ⁽¹⁾	0.4 MPa, 60 psi	○ ⁽²⁾
	P6 ⁽¹⁾	0.6 MPa, 90 psi	○ ⁽²⁾
	P7 ⁽¹⁾	0.7 MPa, 100 psi	○ ⁽²⁾
P10 ⁽¹⁾	1.0 MPa, 150 psi	○ ⁽²⁾	
	+		
② Connection thread	01	R 1/8	●
	02	R 1/4	●
	+		
③ Special specification	—	—	●
	X2	Stud parts nickel plated	●
	X3 ⁽³⁾	Wetted parts stainless steel	●
	X4	Oil-free (Wetted parts degrease washing)	●
	X30	Both MPa and psi	○ ⁽²⁾

Note 1) This symbol must be used with Special specification "X30."

Note 2) Under the New Measurement Law, products for overseas use only (SI unit type for use in Japan)

Note 3) Movable parts (gear, etc.) inside pressure gauge are made of brass.

Note 4) Cover ring assembly is not available.

Dimensions (Except Made-to-Order products)

G43-□-01 to 02

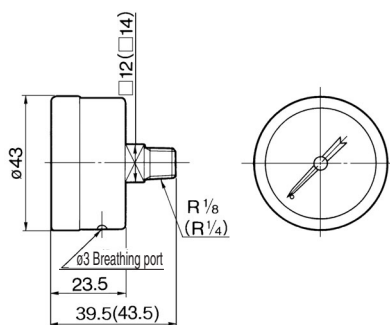

* The dimensions in (): Connection thread R 1/4

Oil Free/External Parts Copper Free Pressure Gauge

G46E (DT type)

O.D.: $\phi 42$

RoHS

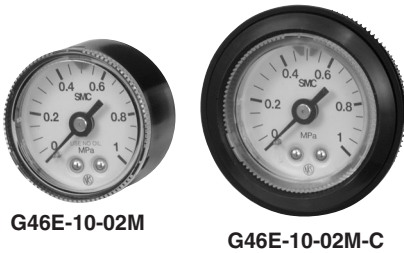

G46E-10-02M

G46E-10-02M-C

Dimensions

* The dimensions in ():
Connection thread R 1/4

G46E-□□-01 to 02 (M)

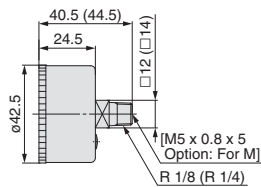

With cover ring assembly (For panel mount)

G46E-□□-01 to 02 (M)-C

Type C (Clear cover is not removable.)

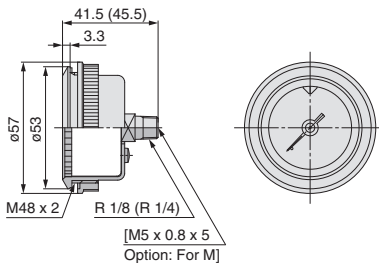

G46E-□□-01 to 02 (M)-C2

Type C2

(Clear cover is removable. The wrench flats protrude.)

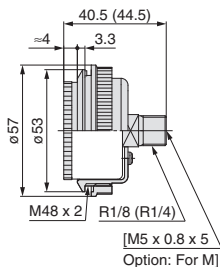

Panel fitting dimensions
Plate thickness Max. 3.5 t

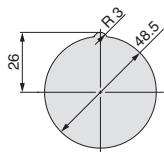

Standard Specifications

Model		G46E
Type		Back side thread
Port size ⁽¹⁾		R 1/8, R 1/4 (Option M: with M5 female thread)
Fluid ⁽³⁾		Air
Indication precision ⁽⁴⁾		±3% F.S. (Full span)
Fluid contact part cleaning		Wetted parts degrease washing
Material	Case (Surface treatment)	Rolled steel (Black melamine painted)
	Clear cover (Surface treatment)	Polycarbonate (Hard coated) Part no.: G46-00-00-2
	Stud (Surface treatment)	Brass (Electroless nickel plated)
	Bourdon tube	Brass ⁽²⁾
Weight (kg)		0.08
Attachment: With cover ring assembly	C	Part no.: 1305104-1A
	C2	Part no.: 1305104-9A

Note 1) When mounting a pressure gauge, use caution not to tighten excessively. Excessive tightening will cause product failure. Use a pipe tape for sealing.

Note 2) Bourdon tube and internal movable parts (gear, etc.) are made of brass and are not electrolessly nickel plated. This is not an internally copper-free product.

Note 3) Avoid freezing as this may cause a malfunction.

Note 4) The guaranteed temperature range is 23°C ±5°C.

Model (Standard)

Model	Pressure range ⁽¹⁾		Indication unit	Connection thread	Note
	MPa	psi			
G46E-2-01 to 02M	0 to 0.2	—	MPa	R 1/8 R 1/4 M5 (Female thread)	—
G46E-4-01 to 02M	0 to 0.4	—			
G46E-7-01 to 02M	0 to 0.7	—			
G46E-10-01 to 02M	0 to 1.0	—			

Note 1) Do not apply pressure more than the maximum display pressure. This will cause a malfunction.

Model (Made to Order)

Other versions of this unit can be made on a Made-to-Order basis.
Please consult SMC for details, as delivery times may be extended.

Model	Pressure range ⁽¹⁾		Indication unit	Connection thread	Note
	MPa	psi			
G46E-2-02M-C/C2	0 to 0.2	—	MPa	R 1/8 R 1/4 M5 (Female thread)	With cover ring assembly
G46E-4-02M-C/C2	0 to 0.4	—			
G46E-7-02M-C/C2	0 to 0.7	—			
G46E-10-02M-C/C2	0 to 1.0	—			
G46E-P2-01 to 02M-C/C2-X30 ⁽²⁾	0 to 0.2	0 to 30	MPa, psi	R 1/4 M5 (Female thread)	
G46E-P10-01 to 02M-C/C2-X30 ⁽²⁾	0 to 1.0	0 to 150			

Note 1) Do not apply pressure more than the maximum display pressure. This will cause a malfunction.

Note 2) Under the New Measurement Law, products for overseas use only (SI unit type for use in Japan)

Pressure Gauge Guide

Gauge for Clean Regulator/With Limit Indicator

G46-■-■-SR

O.D.: $\phi 42$

RoHS



G46-10-02-SR

Standard Specifications

Model	G46-□-02-SRA	G46-□-02-SRB
Type	DT type (Back side thread)	
Precision	±3% F.S.	
Fluid contact part cleaning	Precise cleansing	General degreasing
Assembly/Adjustment environments	Clean room	General production line
Oil/Water free	Oil/Water free	
Material	Fluid contact part	Stainless steel 316
	Case	Stainless steel 304 (Black melamine plated)
	Clear cover	Poly-carbonate (Hard coated) Part no.: G46-00-00-2
	Inner equipment	Brass

Dimensions

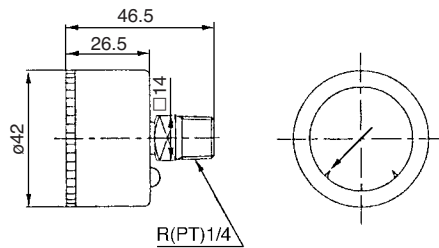

Model (Standard)

Model	Pressure range	Indication units	Connecting thread	Note
	MPa			
G46-2-02-SRA	0 to 0.2	MPa	R(PT)1/4	—
G46-2-02-SRB				
G46-4-02-SRA	0 to 0.4			
G46-4-02-SRB				
G46-7-02-SRA	0 to 0.7			
G46-7-02-SRB				
G46-10-02-SRA	0 to 1.0			
G46-10-02-SRB				

Pressure Gauge Guide

Procedure for setting the limit gauge indicator

- (1) Before setting the (green) limit indicator, turn the cover counterclockwise (approximately 6 to 7mm) until it stops. Then, remove by pulling it towards you.

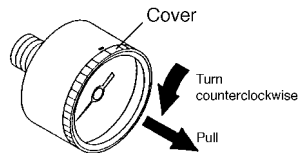

- (2) Use a flat head screwdriver (with a 2.9mm blade width) to set the (green) limit indicator. Be careful not to bend the other needle or damage the dial plate.

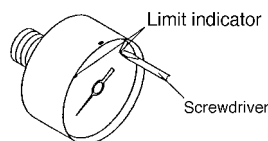

- (3) After completing the setting, replace the cover. Fit the cover by aligning the cutout in the cover to the groove on the top of the black case. Turn the cover clockwise (approximately 6 to 7mm) and make sure that the matching mark on the cover is aligned with the groove on the top of the case.

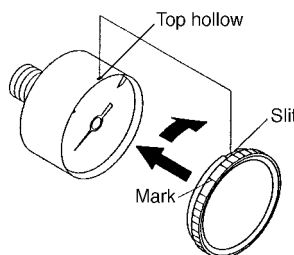

⚠️ Precautions

Be sure to read before handling. Refer to p.0-26 and 0-27 for Safety Instruction and common precautions on the products mentioned in this catalogue.

Selection

⚠️ Caution

- ① Do not apply high load voltage (current) or surge current as this can cause the switch to malfunction.
- ② Make sure that no direct impact or vibrations are applied to the body.
- ③ If operating under pressure pulsations or in high frequency operations, contact SMC.

Installation

⚠️ Caution

- ① During transport and installation, do not apply shock to the product, such as by dropping doing so will affect its precision.
- ② In terms of its installation posture, place it perpendicular to the ground, with the zero point on the dial of the pressure gauge facing down.
- ③ Do not install it in an area that is exposed to high temperature or humidity, because doing so will lead to improper operation.
- ④ To screw in the pressure gauge, make sure to turn the gauge by placing a wrench over the square wrench flats. If the pressure gauge is screwed in by holding it on some other area, it could lead to air leakage or damage.

Procedure for setting the limit gauge indicator and the setting needle

- (1) Before setting the limit indicator and the (green) setting needle, turn the cover counterclockwise (approximately 6 to 7mm) until it stops. Then, remove by pulling it towards you.

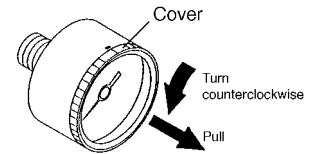

- (2) Use a flat head screwdriver (with a 2.9mm blade width) to set the (green) limit indicator. Be careful not to bend the other needle or damage the dial plate.

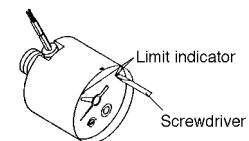

- (3) Before setting the setting needle, use a flat head screwdriver (with a 2.9mm blade width) to turn the setting screw and set the setting needle to the set pressure.

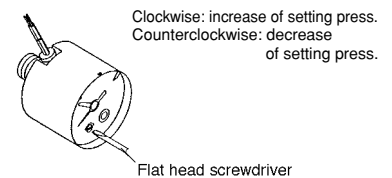

- (4) After completing the setting, replace the cover. Fit the cover by aligning the cutout in the cover to the groove on the top of the black case. Turn the cover clockwise (approximately 6 to 7mm) until it stops. Make sure that the matching mark on the cover is aligned with the groove on the top of the case.

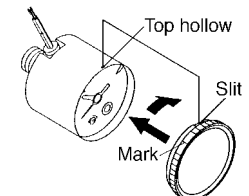

Procedure for assembling the cover ring assembly

• General purpose gauge

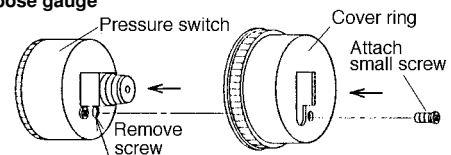

• Gauge with pressure switch

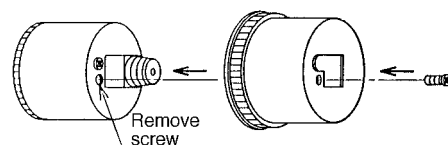

1. Remove the small screw (1 position) from the pressure gauge.
2. Place the cover ring on the pressure gauge.
3. Using the small screw that is provided with the cover ring, install the over ring. The installation torque is 0.3 to 0.5N.m.